

INCH

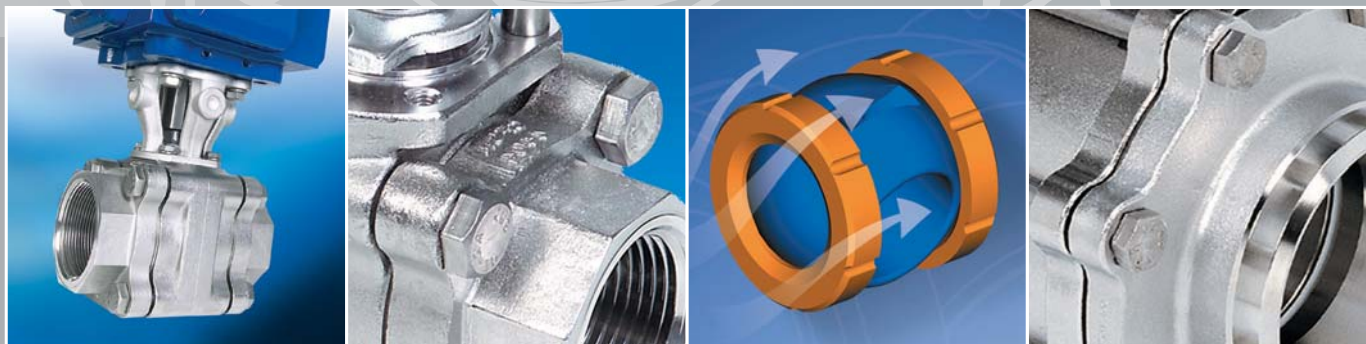

## THREE PIECE BALL VALVES

47P/46 SERIES



DEDICATED TO INNOVATION

# THREE PIECE BALL VALVES

The **47P/46 Series** are the main lines of **HABONIM** 3-piece ball valves for industrial applications. The valves are suitable for applications requiring high flow capacity and tight shutoff, where reliability, functionality and interchangeability are essential for the product quality. **HABONIM** has various valve solutions and designs that give the end user the freedom of choice for the toughest requirements imposed by the industry and by international standards.

## Technical Summary

<b>Size Range:</b>	¼" - 8"
<b>Application:</b>	General Service, Chemical, Petrochemical, Oil and Gas, Refinery, Energy, Pharmaceutical, Food & Beverage, Cosmetics, Semiconductor
<b>Service:</b>	Water, Gas, Steam, Chemicals, Solvents, Thermal Fluid
<b>Pressure Range:</b>	Vacuum 10-6 torr to 3000 psig (210 bar)
<b>Temperature Range:</b>	-40°F to 660°F (-40°C to 350°C)
<b>Materials:</b>	Carbon Steel, Stainless Steel, Hasteloy-C, Hasteloy-C22, Alloy-20, Monel, Duplex, SMO 254
<b>End Connection:</b>	Screwed, Socket & Butt weld, Flanged, Clamp, Compression Fitting
<b>Standards:</b>	Firesafe to API 607 4 <sup>th</sup> Edt. and EN 12266-1:2003
<b>Operation:</b>	Hand or Gear operated, Pneumatic or Electric Actuated

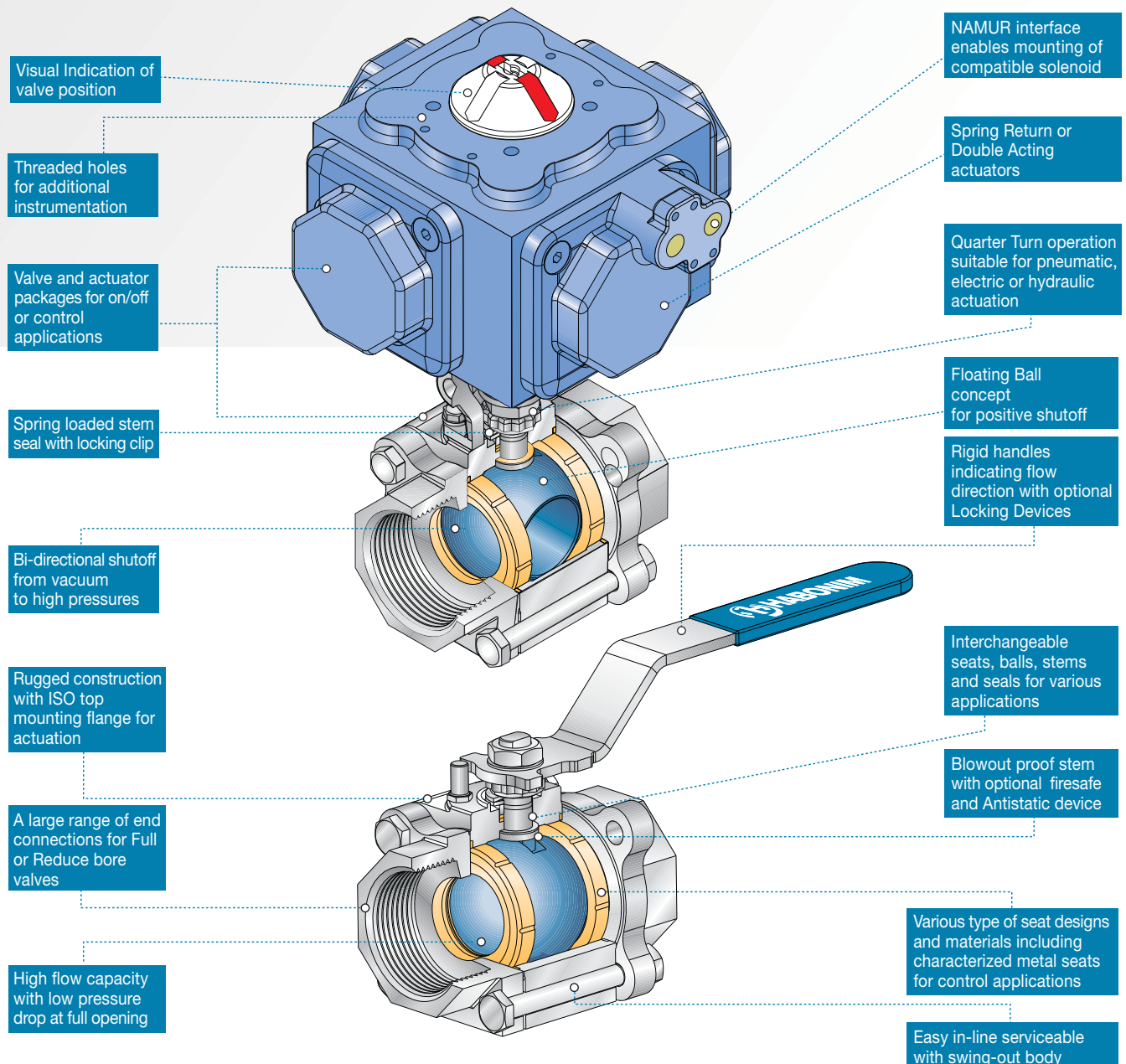

## Valve Construction

The rigid valve body construction is designed in accordance with ANSI B16.34 and BS 5351. The 47P series valve bodies have a top mounting flange conforming to ISO 5211 with centering ring for direct mounting of actuators, limit switches, fugitive emission bonnets or extended handles.

The 46 series valve bodies do not have an ISO top mounting flange and they carry a different wrench (see page 10).

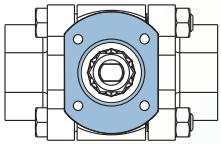

**47P top mounting flange for Actuation & Accessories**

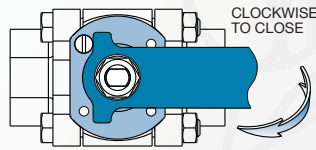

**47P top mounting flange for Manual Operation**

The 3-piece body construction enables valve in-line maintenance and replacement of internal parts. Standard 47P valve bodies have through body bolts. Firesafe valves have threaded body screws. With the ISO mounting flange there is no need to loosen body bolts when fitting actuators.

The 47P/46 series ball, seats and seals are interchangeable with HABONIM flanged 31/32 series reduced bore valves and with HABONIM flanged 73/74/78 series full bore valves up to and including 2". Stem assemblies are interchangeable through out.

## End Connections

Many types of end connections are made to suit most customer requirements. The standard types are screwed, welded or flanged connections.

### Screwed Ends

Screwed ends are identified by a marking on the end face:

**BSPT** - no identification

**NPT** - concentric groove

**BSPP DIN 2999** - external chamfer

**DIN 3852** - external step

Other screwed ends identification will be advised on request.

### Pipe weld Ends

Welded ends are available according to the pipe type and schedule in butt weld or socket weld. The standard pipe schedule is 40. Butt weld ends are available from Sch 5 to Sch 180 and socket weld ends are available up to Sch 40 in reduce bore and up to Sch 80 in full bore.

### Tube weld ends

Tube ends are available in imperial or metric sizes. The ends are short stubs or one piece extended stubs suitable for AOW (automatic orbital welding). Weld end valves can be installed in-line without dismantling the valve or changing internal parts, as long as the proper welding procedures are kept. Please refer to Habonim Welding Instructions for more information.

### Flanged Ends

Flanged ends complying to class 150 ANSI B16.5 and DIN 3202 F1 face-to-face dimensions are available in reduce or full bore. In some cases ANSI flange end valves will comply to class 300 face-to-face dimensions only.

## Body and Trim Materials

Standard HABONIM body and end materials are **Carbon Steel** or **Stainless Steel**. Carbon Steel bodies and ends are forgings to ASTM A105 or castings to ASTM A216 WCB. Stainless Steel bodies are casting to ASTM A351 CF8M. The ends are castings to ASTM A351 CF3M, which have a lower carbon content and are therefore more suitable for welding.

The standard ball and stem material is stainless steel 316. All high torque valve stems are in high tensile 17-4PH stainless steel. Balls in 17-4PH stainless steel are also available. Other valve and trim materials such as Alloy-20, Hastelloy-C22, Duplex or Monel for specified applications are available on request.

All valve pressure containing parts such as bodies and ends are heat numbered and can be traced by their work number which is stamped on the valve tag. Documentation will be supplied on request.

Stainless steel valves have stainless steel bolts and nuts. Carbon steel valves have plated carbon steel bolts and nuts. Special alloy valves carry stainless steel bolts and nuts unless otherwise specified.

## Other Ends

Other available ends are Clamp ends for the Biopharm and Food industry, Compression Fitting ends for Instrumentation and the Semiconductor industry, Extended Pipe ends for the Chemical industry. Other ends are available on request. Please refer to Bulletin C-515 for dimensions.

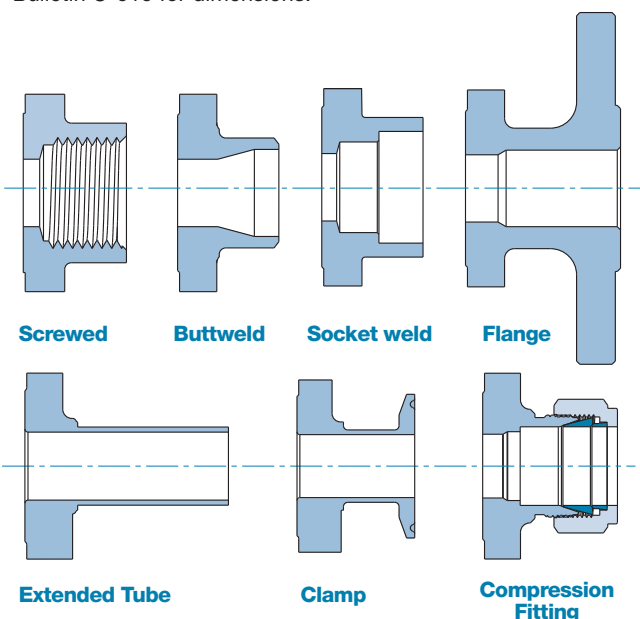

# THREE PIECE BALL VALVES

## Floating Ball Principle

The floating ball design is based on the concept that both the **seat preload** and the **line pressure** contribute to a compressive force between the ball and seat to create a bubble tight shut-off at low and high pressure drops. The line pressure forces the ball to the downstream seat, the seat flexes and creates the seal. The upstream seat is forced forward, allowing the pressure to penetrate from behind through the grooves and into the body cavity, relieving the load and reducing its wear. Other designs such as diverter and double block and bleed seats, incorporate a "seat/seal" or seat with a backup O-ring to seal from the upstream side of the valve.

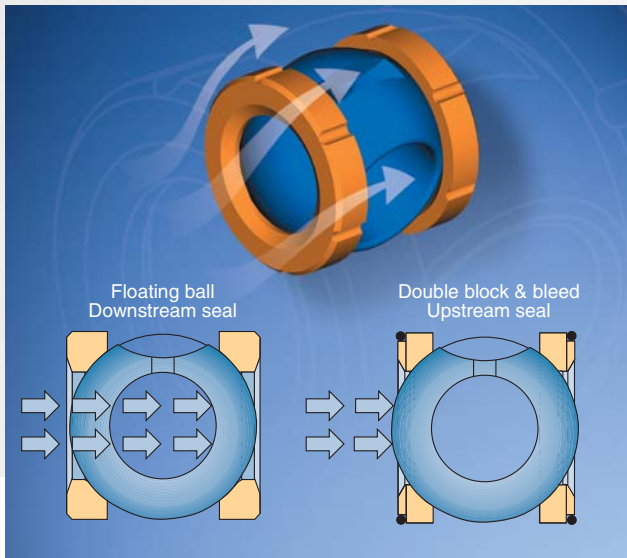

## Ball Material

A highly polished solid ball ensures tight shutoff and long service life. All balls are solid and have specially rounded leading edges to eliminate excessive seat wear during rotation. The balls have a hole in the stem slot to equalize pressure behind the ball in the valve cavity (see illustration below). Standard ball materials are 316 Stainless Steel, Hasteloy-C, Monel, Alloy-20, Duplex and Inconel. All materials (except 316 SS) are marked in the slot for identification.

Other ball designs such as diverter balls, cavity pressure relief balls with a vent hole to the upstream side, characterized port balls for control applications, balls for flushing body cavity and more are available on request (see illustrations below).

Equalizing pressure hole in slot

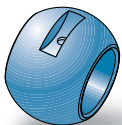

Upstream pressure relief hole

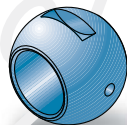

Characterised port for control

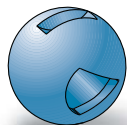

T-Port for flushing

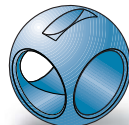

## Body Seals

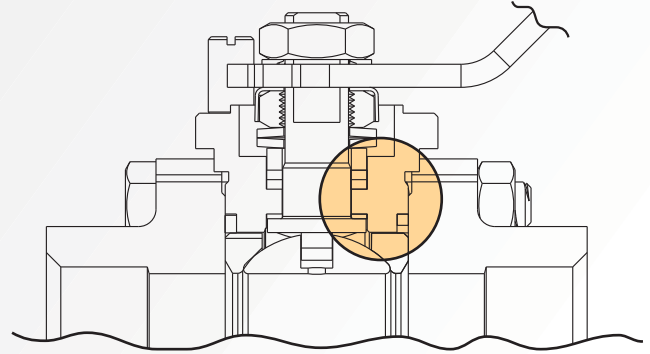

### Standard Body Seal

The body seal in a standard valve is constructed with three closed sides and one side open into the valve cavity. Pressure in the valve cavity forces the seal to the corners, thus creating a tight seal. All seal materials are flexible and will compress according to the groove shape. Each time the valve is opened for repair, the seals must be replaced with new ones.

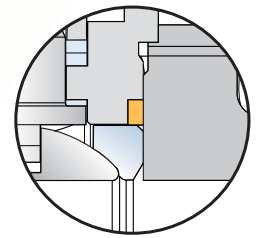

### Metal Ring

The Metal Ring Encapsulated Groove design uses a thinner body seal supported by a metal ring and is used in the standard body. It provides tighter compression of the body seal for higher pressure and temperature fluctuations. It also serves a barrier for all flexible graphite body seals from penetrating into the valve body.

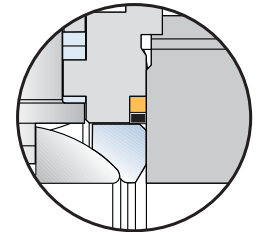

### Encapsulated Groove

The fully Encapsulated Groove body serves the same purpose as the Metal Ring design, only the groove is machined in the valve body.

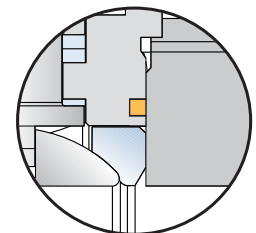

This body construction utilizes the same seals without the metal ring.

### Tongue & Groove

The Tongue & Groove design is used in all firesafe valves and is intended to allow full compression of the flexible graphite body seal and the alignment of the body and ends. This is implemented by having the body seal groove in the end connector and not in the body. Firesafe bodies and end connectors are not interchangeable with the standard bodies and ends.

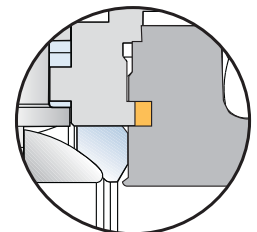

## Reduced Bore and Full Bore

**HABONIM's 47P/46 series** valves are “**Reduced Bore**”, (Nominal Bore) where the ball port ID is reduced from the nominal pipe ID. This reduction creates a pressure drop across the valve and must be considered when doing flow calculations.

**HABONIM's B47P/B46 series** valves are “**full bore**”, where the ball port ID matches the nominal pipe ID. The full bore valve has “one-size-up” body and trim with a “full bore” end connection. Full bore valves are used when maximum flow at minimum pressure drop is required.

All the types of end connections are available in both reduce bore or full bore.

For any fixed nominal pipe size you can have a “reduced bore” valve with regular ends, or a “full bore” valve with full bore ends and “one-size-up” body and ball. This is illustrated below:

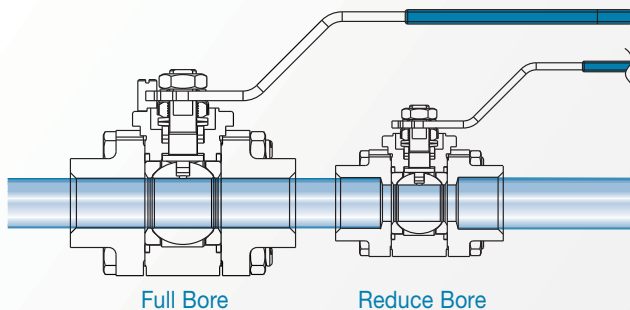

## Stem

A precision machined blowout-proof stem is inserted into the valve body from within. Available as standard, antistatic or firesafe. The firesafe stem has a special contour for metal to metal contact in the event of fire. Stems ½” to 2½” output shaft are double “D”. Stems 3” and above have square shaft as standard and double D can be provided upon request by mentioning “WR” Stem

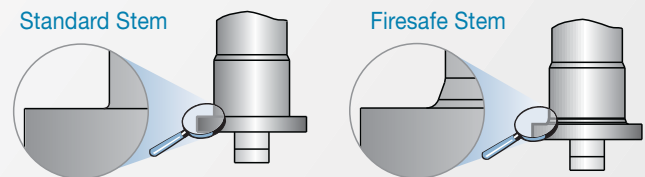

## Antistatic Device

Antistatic stem device to discharge static electricity buildup on the ball are optional. This conforms to BS 5351 for continual electrical contact between ball/stem and stem/body. Contact is made by a spring loaded stainless steel element inserted in the stem or a conductive PTFE stem seal. Valve sizes up to 2” require a stem/body contact, while larger size valves also need a ball/stem contact.

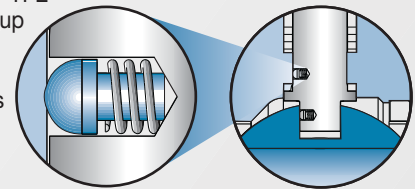

## Stem Assemblies

All valves have blowout-proof stems. The stem assembly incorporates live loaded springs to compensate for pressure and temperature surges and wear. A tab washer ensures that the stem nut will not loosen during cyclic operations. The stem is machined with a high surface finish for better sealing capability. Optional stem seal materials and shapes are available. Special High Cycle stem arrangements are available for specific applications.

### Standard Stem Assembly Sizes ½” to 2½”

A blowout-proof stem and thrust washer are inserted in the valve body from its cavity. A set of one or two stem packings followed by a stem-centering gland are spring loaded and fastened by a nut and tab washer from the outside. A rigid handle is fastened above it by a second nut and serrated washer.

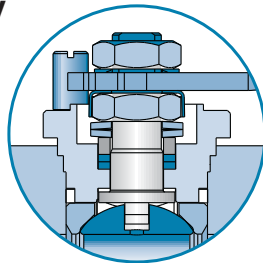

### Standard Stem Assembly Sizes 3” to 8”

A blowout-proof stem and thrust washer are inserted in the valve body from its cavity. A set of three stem packings followed by a stem-centering gland and stop plate are fastened by a slotted gland nut from the outside. A pipe wrench is inserted into a “TEE” head and fastened by a screw to the stem.

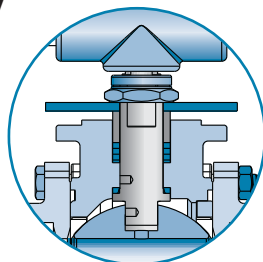

### O-Ring Stem Assembly

O-ring stem assemblies for searching gas, high vacuum and other special applications such as ammonia or high cycle applications are standard options. The O-ring, followed by backup rings, is secured in place by a metal washer and bearing.

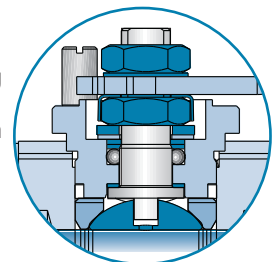

### V-Ring Stem Assembly

V-ring or sandwich style stem seals are some times more efficient for applications such as high cycle or where it is essential to have low emissions. These seals can be fitted into the standard valve body.

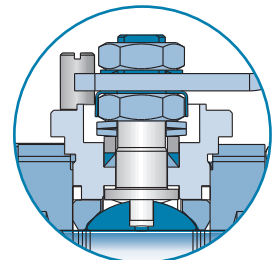

### High Cycle Stem Assembly

In high cycle applications where the valves may pass through many operational cycles per year, an upgrade to the stem assembly is done according to the working conditions. Thrust seal with better wear resistant material, hardened polished stems and special stem seals are suggested. A unique gland with an O-ring groove secured by a live-loading spring-pack give the valve long service life.

# THREE PIECE BALL VALVES

## Seats Type and material

A flexible seat design provides tight shutoff at high and low pressures, reduces wear and valve torque. The seat perimeter has equalizing pressure slots to allow penetration of pressure to the body cavity for better sealing capability.

Other available seat designs are Cavity Filler seats for reducing dead volume in the ball cavity, One-piece Seat/Seal for diverter valves or Double-Block and Bleed seats with O-ring.

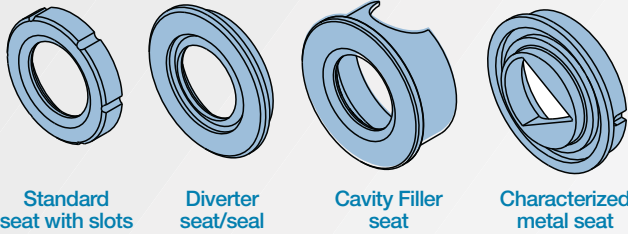

Habonim has a line of metal seated valves for severe service applications where high temperature, abrasion and/or corrosion restrict the use of soft seats. Please refer to Habonim

[Bulletin T-624](#) for additional information on seat materials and pressure temperature limits.

### T PTFE

PTFE is the material of choice where the characteristics of low friction, high durability, excellent thermal resistance or chemical inertness are required. Recommended for use with water, foodstuff or corrosive chemicals.

Identification: Color white.

### A TFM™ (Modified PTFE)

TFM™ is a chemically modified PTFE™ that offers enhanced properties while retaining all the proven advantages of conventional PTFE.

Identification: Color white with brown stripe.

### J R Glass Filled PTFE

Glass filled PTFE has virtually the same chemical compatibility as virgin PTFE but extends the pressure/temperature rating of the valve. Its superior compression and heat resistance provide the seat good wear resistance at high loads and is particularly good for steam application.

Available with glass fibre content of 15% (R) or 25% (J).

Identification 15% GF: Color off-white with blue stripe.  
Identification 25% GF: Color off-white with red stripe.

### P Carbon Filled PTFE (NRG)

NRG seats are suitable for elevated temperatures, resistance under high pressure loads, low coefficient of friction and are suitable for many corrosive applications. They are available in two different profiles to suit both steam or thermal fluid at high temperature and cryogenic applications.

Identification: Color charcoal black with white stripe.

### H Glass & Metal Oxide Filled PTFE

This seat withstands higher temperatures and pressures than glass filled PTFE, has good resistance under load, not recommended for foodstuff

Identification: Color blue.

### U UHMWPE (Ultra High Molecular Weight Polyethylene)

UHMWPE is mainly used where PTFE is not acceptable. It has high radioactive resistance of 2 x 10 rads. Other typical applications are the tobacco industry, H<sub>2</sub>SO<sub>4</sub> and the handling of highly abrasive media.

Identification: Color pale white with green stripe.

### Y Delrin® (Acetal Resin)

Delrin® is used for high pressure applications where resistance to wear and deformation under load is essential. It is mainly used in the Petroleum industry. Its maximum temperature is limited to 176°F (80°C) under full load.

**Delrin® must not be used in presence of OXYGEN.**

Identification: Color creamy white with black stripe.

### K Carbon Filled PEEK®

PEEK® (Polyetheretherketone) is a tough, high temperature, semicrystalline thermoplastic offering excellent characteristics such as high tensile strength and elongation properties, excellent shear strength and creep resistance, outstanding fatigue and chemical resistance, no susceptibility to hydrolysis (Steam/Hot Water).

Identification: Color black with yellow stripe.

### L Virgin PEEK®

Virgin PEEK® has no fillers and comprises similar physical characteristics as filled PEEK®. It has higher radiation resistance and is suitable for food, tobacco and pharmaceutical applications.

Identification: Color beige.

### S Vespel®

Vespel® is a polyimide material that has high temperature capabilities under load and is mainly used for heat transfer applications, hot gases and oils.

**Vespel must not be used in with STEAM or media containing WATER or WATER VAPOR.**

Identification: Color brown.

### C PCTFE (Kel-F®)

PCTFE material, better known as Kel-F® (Chloro Tri Fluoro Ethylene) is used extensively for cryogenic services for temperatures down to -320°F (-196°C) to 250°F (121°C). Its main applications are for gas production, transportation and storage.

Identification: Color see through white.

## Pressure / Temperature Rating (Seat Material)

The solid lines in the Pressure/Temperature (PT) graphs are the maximum seat rating for each material\*, and are not the valve body rating. Valves above 2" have a limiting body rating

of #300 for all seat material. The PT lines are based on differential pressure with the valve in the closed position. Data is given from field applications and laboratory tests.

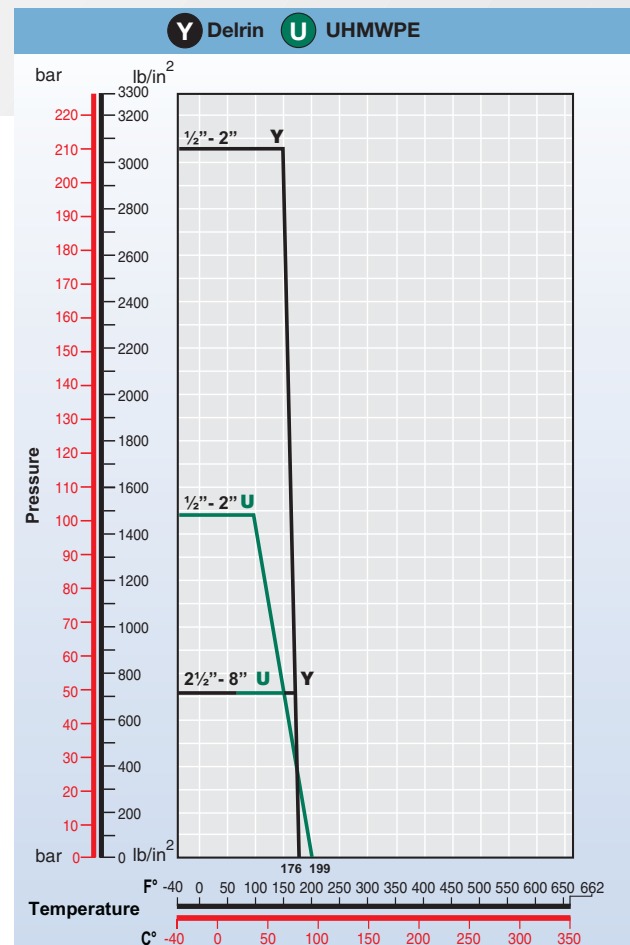
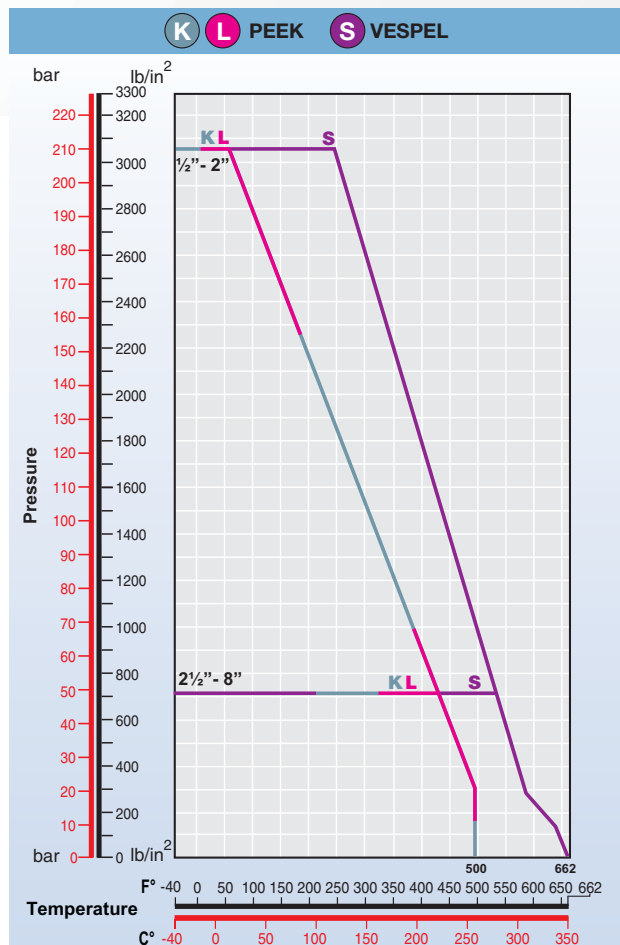
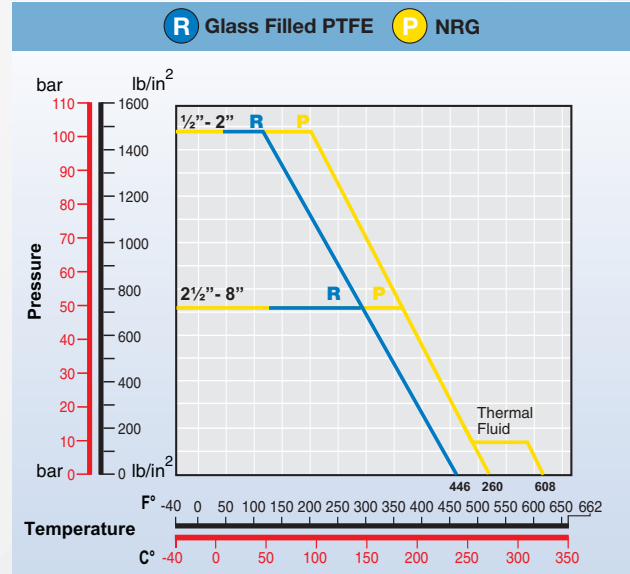
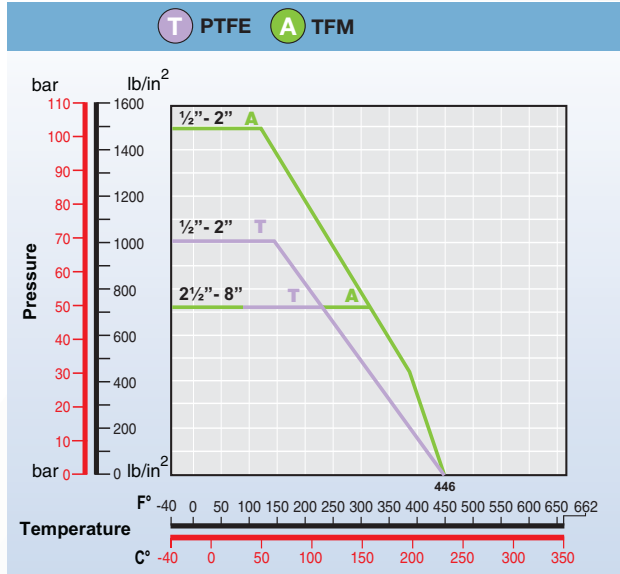

\* Additional information of other seats material is available on request.

# THREE PIECE BALL VALVES

## Main Valve Applications

Some of the main valve applications that Habonim have are specified and detailed below. For more information on other options, consult with Habonim.

### Firesafe Valves



The “AF” series Fire Safe valves are designed and tested to the requirements of API 607 4<sup>th</sup> Edition and to BS 6755 Part 2 specifications. The valves contain soft seat rings. In the event of fire, a secondary metallic machined ring comes in contact with the ball and prevents leakage through the valve port. The stem incorporates a machined ring shaped surface which will prevent leakage, once the thrust seal has been burned off. All firesafe valves are fitted with flexible graphite body seals and graphite stem seals.

Bulletin: P - 115

### Control Valves



The “N” series V-port control valves are used in many industrial processes such as steam, pH, pressure, temperature and other control applications. The specially mate-lapped hard coated ball and characterised metal seats, matched ball and stem, direct ISO mounting pad and fastened adaptor mounting kit provide reduced hysteresis, precise control and tight shutoff. A wide range of end connectors are available together with various types of seat and seat materials.

Bulletin: P - 411 (characterized & round port)

### Diverter Valves



The “D” and “S” series diverting valves reduce the number of valves in a system, thereby saving cost and giving the user easier control by using a single valve in place of multiple valves. The diverter valve can be used with all the standard end connections and has various types of ball porting.

Bulletin: P - 108

### Instrumentation Valves



The “L” series valves for instrumentation applications are assembled with the “Let-Lok” compression fitting ends. The ends are one-piece casting, machined to fit Imperial or Metric tubing from 1/4” to 1” or 6 mm to 25 mm. Pressure rating up to 3000 psi (210 bar) and temperatures up to 250°C (not combined).

Bulletin: P - 116

### Steam and Thermal Fluid Valves



The “W” series valves for Saturated Steam service up to 35 bar and Heat Transfer Fluids for temperatures up to 320°C have NRG, PEEK or VESPEL\* seats, encapsulated graphite body seal and graphite stem packing. The valve has a red sleeved handle for identification and is available with stem extension for actuation.

Bulletin: P - 113

\* VESPEL must NOT be used with steam.

### High Pressure Valves



Valves for high pressure applications in 46 and 47P series include Acetal Resin (Delrin) seats, Buna-O shore 90 body seals, Nylatron thrust seal and 17-4PH stem material. Valves from 1/4” to 1” are suitable for pressures up to 3000 psi (210 bar) and from 1 1/4” to 2” up to 2300 psi (160 bar). For higher pressures up to 6000 psi (400 bar) please refer to the Habonim H27 series valves.

H27 Series A - 106

### Cryogenic Valves



The “C” series valves for cryogenic service applications are used for speciality gas production, food industry, metallurgy, transportation and other. With a precision welded body and extended bonnet, one piece high tensile stem, PCTFE or NRG seat material and V-shape stem packing, the valves can operate at temperatures down to -196°C (-320°F) and pressures up to 100 bar (1500 psi). All cryogenic valve balls have an upstream pressure relief hole to prevent buildup of pressure in the body cavity.

Bulletin: P - 119

### Clean Valves



The Habonim line of Clean Valve applications include the Semiconductor, Pharmaceutical, Biotechnology, Food and Beverage and Cosmetic industries. Special body and trim material selection, machining procedures, assembly and testing in a class 1000 cleanroom are some of the valve specifications. The “I” series High Purity valves for the Semiconductor industry including the FDS (Fluid Distribution Systems) lateral valves are well proved worldwide. [High Purity Ball Valves](#), [67 Series FDS Valves](#), [Bulletin: P - 140](#)

### Vacuum and Searching Gas Valves



The “V” series valves for high vacuum and searching gas applications include Viton O-ring body seals and a special O-ring stem assembly. The valves are suitable for vacuum down to 10<sup>-6</sup> torr and lower. All valves are assembled, tested and packaged in a cleanroom area. The valve stem assemblies are defined “P043”.

Bulletin: D-502

### Special Application Valves



Valves for Oxygen, Chlorine or Ammonia service are specified “Special Application Valves” and each is manufactured under strict quality conditions. The “O” series valves for Oxygen service require very selective body and trim materials with special cleaning procedures. The “K” series valves for Dry Chlorine service are in accordance with the guidelines of the Chlorine Institute Pamphlet 6. Ammonia service valves have special stem assemblies defined “A0866”. All valves are assembled, tested and packaged in a cleanroom area.

Oxygen Service: D - 503

Chlorine Service: D - 501

## Fugitive Emissions

In applications where it is essential to eliminate escape of volatile organic compounds (VOC) into the atmosphere, a Fugitive Emission kit can be mounted directly onto the top ISO platform of the valves. The kits are available for all sizes and can be operated manually or with an actuator. Each housing has two threaded ports for connecting tubing or instrumentation for registering potential leaks. series ISO platform make the valves ideal for "add-to" such as extended handles, spring return handles and other attachments.

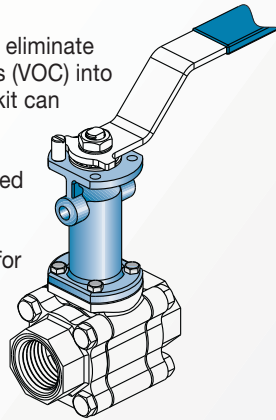

## Cavity Filler Valves

All the 47P and 46 series valves are available with cavity filler seats that eliminate all crevices, gaps and pockets between the ball and valve body and reduce the risk of contaminants being trapped or the solidification of product. The valve body is specially machined to fit the seat/seal dimensions. Cavity filler valve bodies cannot be replaced with standard bodies as they have larger bore dimensions. [Bulletin: P - 117](#)

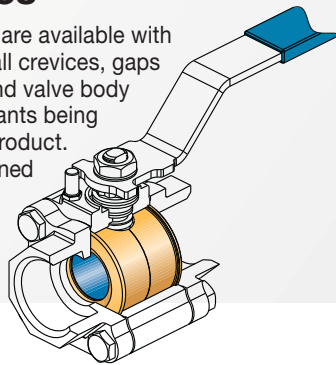

## Diverter Valves

Habonim's line of diverting valves are available in D47P, S47P or 61/62P series. The valves have ball types for any flow pattern. These flow combinations reduce the number of valves in a system, thereby saving costs and giving the user easier control by using a single valve in place of multiple valves. They have the advantage of incorporating the same body dimensions that will allow any standard end connection to be fitted to the valve. The valves incorporate all the additional options of the two way valves including cavity seats (in D47, S47 series only).

[Bulletin: P - 108](#)      [Bulletin: P - 120](#)

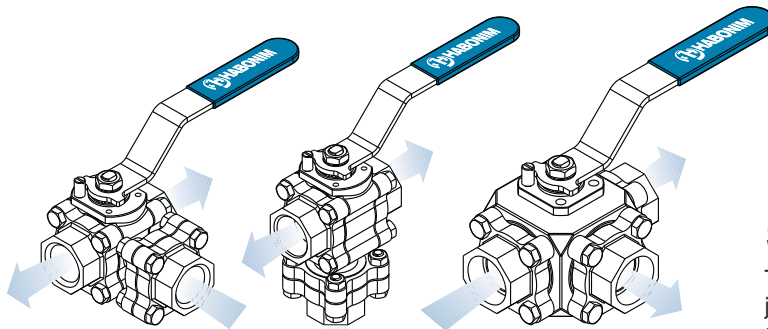

S47P Side Entry

D47P Diverter

61/62P Multi-Port

## Locking Device

### LLP (Locked in Last Position)

The Habonim spring loaded locking device (LD) is ideal for applications where it is critical to keep the valve position without the risk of accidental operation. The locking device fits easily to the valve stem by simply removing the stem nut and threading the lock stem above the handle. The LD can lock the valve in closed or open position. The LD can be fitted to the valve in-line. Available in sizes 1/2" to 2".

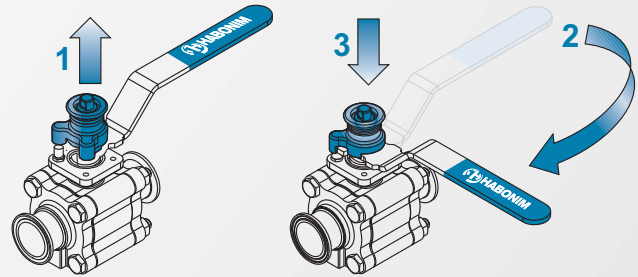

Valve in OPEN position

Valve in CLOSED position

While lifting the lock housing above the stop pin (1) turn the wrench (2) to its new position. When the handle is in its new position release the housing to fit on the stop pin (3).

## Flush Bottom Tank

Valves with special flush tank ends that are welded or bolted flush to the bottom of reactors or vessels allow complete drainage and stirring of product leaving no pockets above the ball. The tank end contour and radius provide effective gravity drainage, removing any traces of liquids. Special or custom designed tank ends are optional. Additional options such as special "C-Balls" for full drainability of body cavity, or purge ports for flushing the valve or the tank are available on request. The valves can be fitted to the piping system with any type of end connector.

[Bulletin: P - 118.](#)

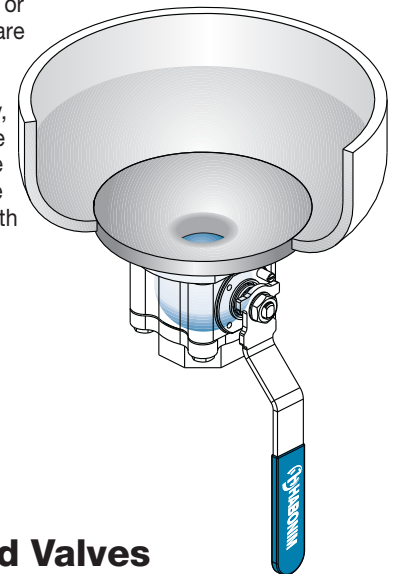

## Steam Jacketed Valves

The 47P and 46 series valves are available with steam jackets for thermal fluids, hot water or steam. The valves are available with any number or type of inlet and outlet ports. The steam jacket is welded to the center body to minimize heat loss.

[Bulletin: C - 511](#)

# THREE PIECE BALL VALVES

## Material Specifications 1/2" - 2 1/2"

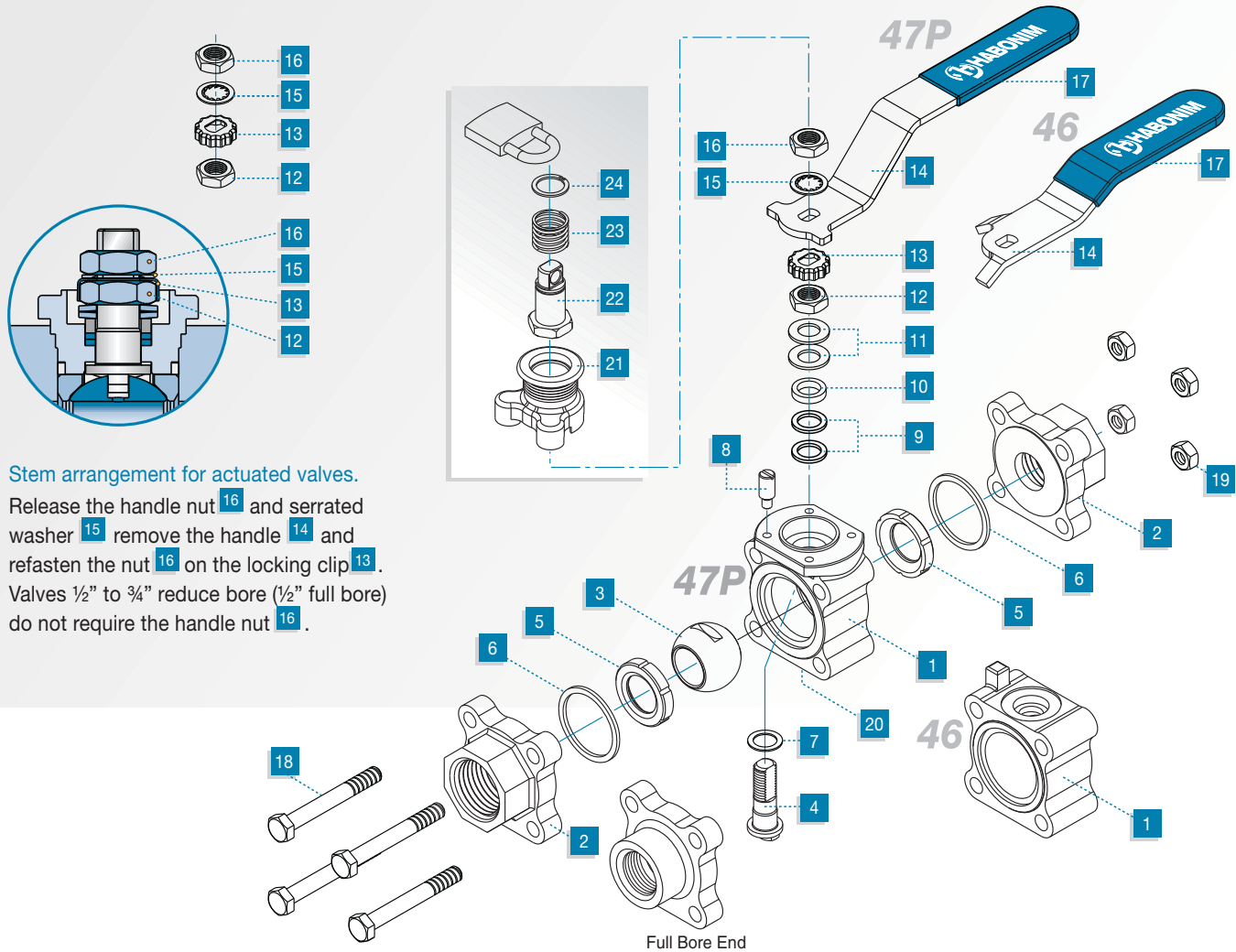

### Stem arrangement for actuated valves.

Release the handle nut **16** and serrated washer **15** remove the handle **14** and refasten the nut **16** on the locking clip **13**. Valves 1/2" to 3/4" reduce bore (1/2" full bore) do not require the handle nut **16**.

Full Bore End

Item	Description	Material Specifications	Qty.
1	Body	Stainless St. ASTM A351 CF8M, Carbon St. A105, WCB, Hasteloy C, Hasteloy C22, Alloy 20, Monel, Duplex, Super Duplex	1
2	End connector	Stainless St. ASTM A351 CF3M, Carbon St. A105, WCB, Hasteloy C, Hasteloy C22, Alloy 20, Monel, Duplex, Super Duplex	2
3	Ball	Stainless St. ASTM A351 CF8M Hasteloy C, Hasteloy C22, Alloy 20, Monel, Duplex, Super Duplex	1
4	Stem	Stainless St. ASTM A276 316 / 316L Hasteloy C, Hasteloy C22, Alloy 20, Monel, Duplex, Super Duplex	1
*5	Seat	PTFE, RPTFE, NRG, PEEK, TFM, UHMWPE, VESPEL, DELRIN	2
*6	Body seal	PTFE, RPTFE, TFM, UHMWPE, Graphite, Metal O -Ring	2
*7	Stem thrust seal	RPTFE, NRG, PEEK, TFM, UHMWPE, VESPEL, NYLATRON	1
8	Stop pin	Stainless St. ASTM A582 303	1
*9	Stem packing	PTFE, RPTFE, NRG, TFM, UHMWPE, Graphite	2

\* Standard items for repair kits

Item	Description	Material Specifications	Qty.
10	Follower	Stainless St. ASTM B783 316L	1-2**
11	Disc spring	Stainless St. ASTM A693 17-7PH	2
12	Stem nut	Stainless St. ASTM A194 316	1
13	Locking clip	Stainless St. ASTM A164 304	1
14	Handle	Stainless St. ASTM A240 430 Carbon St. ST37 ZINC PLATED	1
15	Serrated washer	Stainless St. AISI 410	1
16	Handle nut	Stainless St. ASTM A194 316	1
17	Sleeve	Vinyl Plastisol	1
18	Body bolt	Stainless St. ISO 4014 A2-70 Carbon St. ISO 4014 GR 8.8 zinc plated	4
19	Body nut	Stainless St. ISO 4032 A2-70 Carbon St. ISO 4032 GR 8.8 zinc plated	4
20	Tag (not shown)	Stainless St. ASTM A167 304	1
21	LD housing	Stainless St. ASTM A351 CF8	1
22	LD stem	Stainless St. ASTM A351 CF8	1
23	LD spring	Stainless Steel, Music Wire	1
24	LD circlip	Spring Steel	1

\*\* 2 Followers are used on 1/2" & 3/4"

## Valves Dimensions 1/2"- 2 1/2"

### 47P Series 1/2"- 2" (1/2"- 1 1/2" FB) with ISO top

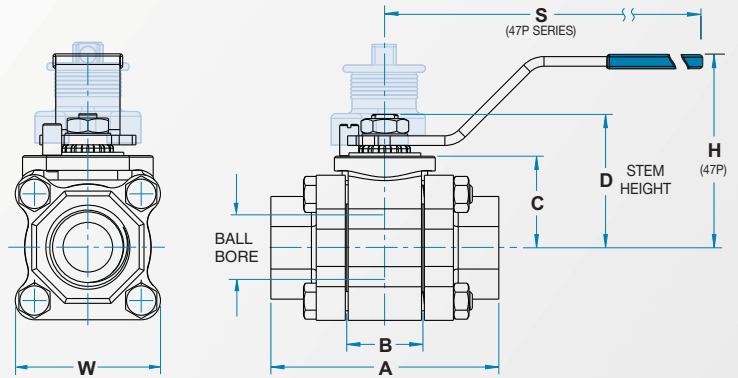
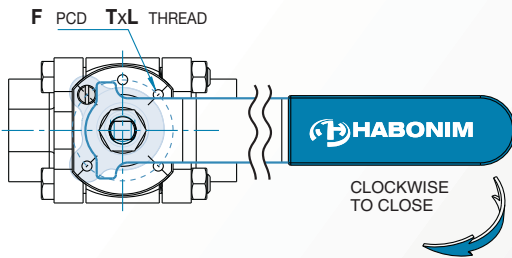

### 46 Series 1/2"- 2" (1/2"- 1 1/2" FB) without ISO top

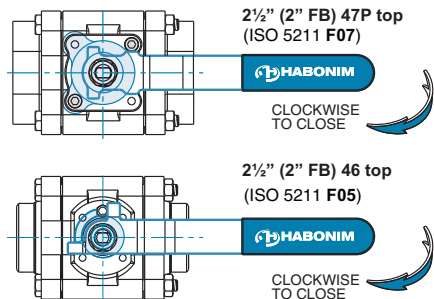
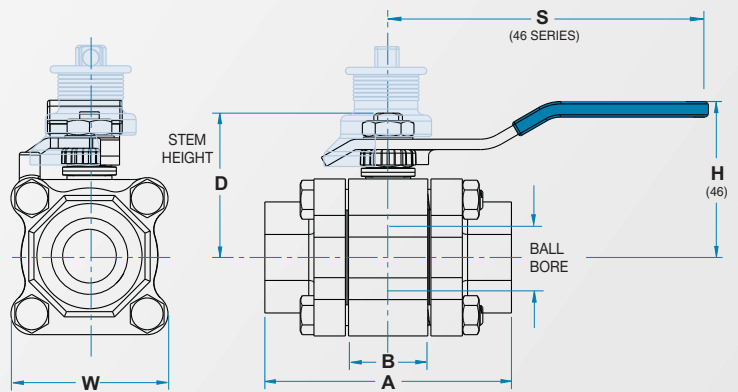
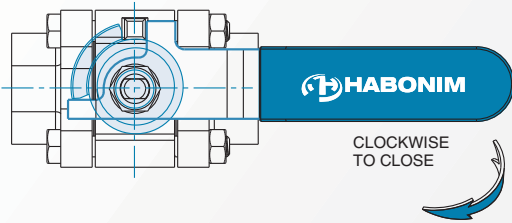

#### STEM DIMENSIONS

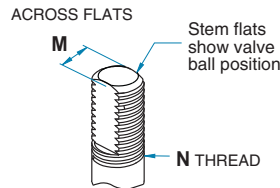

#### PREPARATION FOR ACTUATION

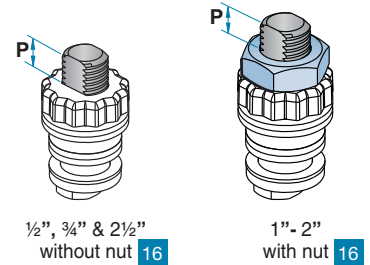

RB	FB	Unit	Bore	A	B	C	D	H(47P)	H(46)	S(47P)	S(46)	W	M	N	P	TxL	F(ISO)	Weight
1/2"	1/4", 3/8"	mm	11.15	66.0	20.6	29.0	38.7	61.5	44.5	150.0	114.0	47.0	5.5	3/8" UNF	7.2	M5x10	F03	0.6 Kg
		inch	0.44	2.598	0.811	1.142	1.524	2.421	1.752	5.906	4.49	1.850	0.217	0.283			F03	1.33 lb
3/4"	1/2"	mm	14.3	70.6	24.5	31.4	40.3	63.9	46.7	150.0	114.0	53.7	5.5	3/8" UNF	7.2	M5x10	F03	0.8 Kg
		inch	0.56	2.779	0.965	1.236	1.587	2.516	1.838	5.906	4.49	2.114	0.217	0.283			F03	1.77 lb
1"	3/4"	mm	20.6	93.7	31.7	38.2	55.6	79.4	60.0	187.0	146.0	63.7	7.54	7/16" UNF	7.2	M5x10	F04	1.6 Kg
		inch	0.81	3.689	1.248	1.504	2.189	3.126	2.362	7.362	5.75	2.507	0.297	0.283			F04	3.54 lb
1 1/4"	1"	mm	25.4	108.0	41.3	42.7	60.2	84.1	64.8	187.0	146.0	71.7	7.54	7/16" UNF	7.2	M5x10	F04	2.5 Kg
		inch	1.00	4.252	1.624	1.679	2.370	3.311	2.551	7.362	5.75	2.822	0.297	0.283			F04	5.53 lb
1 1/2"	1 1/4"	mm	31.8	115.5	48.4	43.6	73.0	97.0	76.5	237.0	178.0	86.7	8.71	9/16" UNF	8.0	M6x12	F05	3.6 Kg
		inch	1.25	4.547	1.906	1.717	2.874	3.819	3.011	9.331	7.00	3.413	0.343	0.315			F05	7.96 lb
2"	1 1/2"	mm	38.1	128.0	56.3	48.3	77.8	101.8	81.2	237.0	178.0	96.9	8.71	9/16" UNF	8.5	M6x12	F05	4.5 Kg
		inch	1.50	5.039	2.217	1.902	3.063	4.008	3.197	9.331	7.00	3.815	0.343	0.334			F05	9.95 lb
2 1/2"	2"	mm	50.8	158.0	72.6	70.0	88.1	115.1	112.1	237.0	287.0	108.0	8.71	9/16" UNF	13.5	M8x12	F07	9.5 Kg
		inch	2.0	6.220	2.858	2.756	3.469	4.531	4.413	9.331	11.3	4.252	0.343	0.531			F07	21.0 lb

# THREE PIECE BALL VALVES

## Material Specifications 3"- 8"

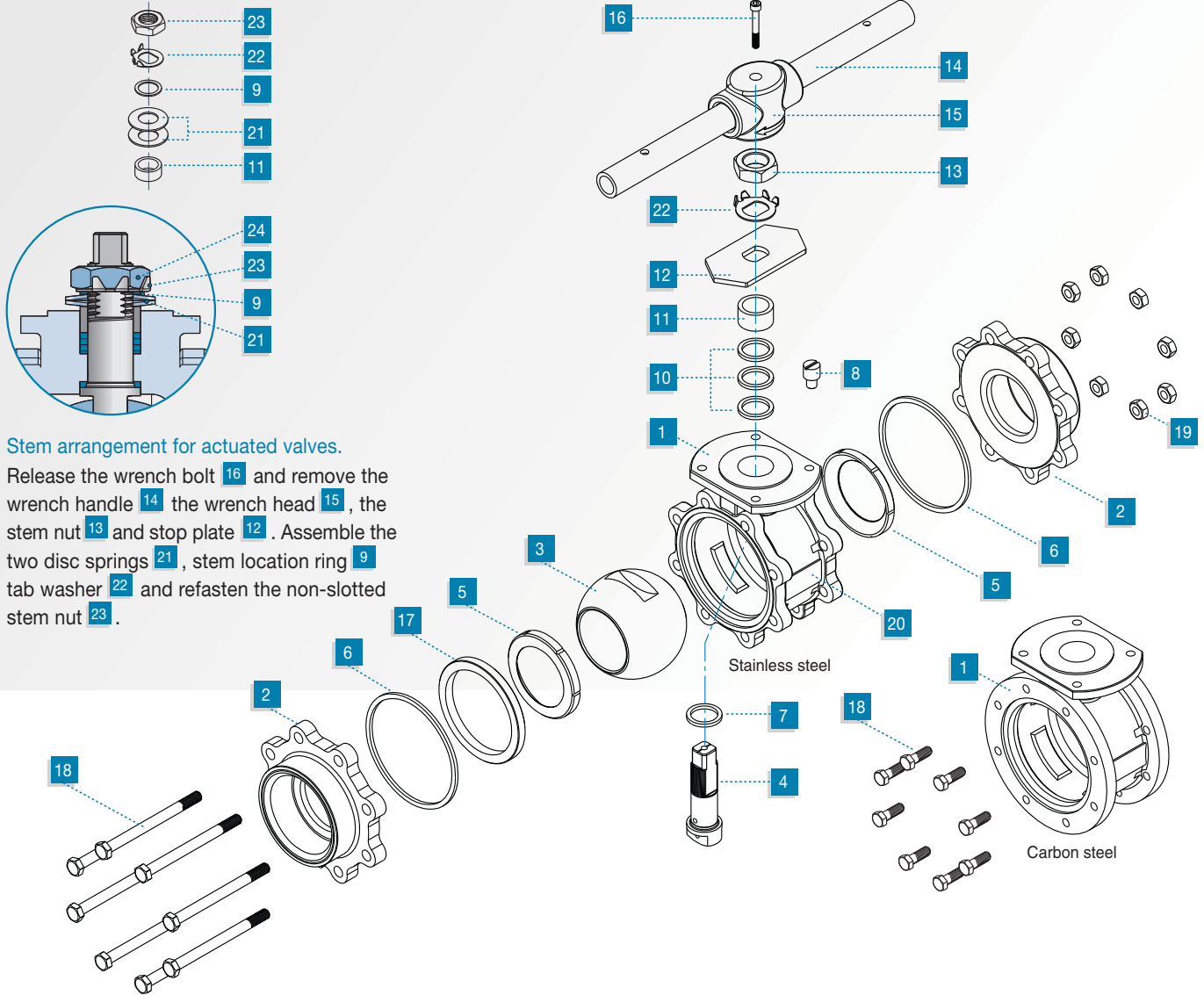

### Stem arrangement for actuated valves.

Release the wrench bolt 16 and remove the wrench handle 14, the wrench head 15, the stem nut 13 and stop plate 12. Assemble the two disc springs 21, stem location ring 9, tab washer 22 and refasten the non-slotted stem nut 23.

Item	Description	Material Specifications	Qty.
1	Body	Stainless St. ASTM A351 CF8M, Carbon St. ASTM A216 WCB	1
2	End connector	Stainless St. ASTM A351 CF3M, Carbon St. ASTM A216 WCB	2
3	Ball	Stainless St. ASTM A351 CF8M	1
4	Stem	Stainless St. ASTM A276 316 / 316L	1
*5	Seat	PTFE, RPTFE, NRG, PEEK, TFM, UHMWPE, VESPEL, DELRIN	2
*6	Body seal	PTFE, RPTFE, TFM, UHMWPE, Graphite, Metal O -Ring	2
*7	Stem thrust seal	RPTFE, NRG, PEEK, TFM, UHMWPE, VESPEL, NYLATRON	1
8	Stop pin	Stainless St. ASTM A582 303	1
*9	Stem locking ring	Stainless St. ASTM A240 316	1
*10	Stem packing	PTFE, RPTFE, NRG, TFM, UHMWPE, Graphite	3
11	Follower	Stainless St. ASTM B783 316L	1

\* Standard items for repair kits

Item	Description	Material Specifications	Qty.
12	Stop plate	Stainless St. ASTM A240 430 Carbon St. ST37 ZINC PLATED	1
13	Stem nut	Carbon St. Zinc Plated	1
14	Wrench handle	Stainless St. 304 Carbon St. Zinc Plated	1
15	Wrench head	ASTM A47 Maleable Iron	1
16	Wrench bolt	Stainless St. ISO 4014 A2-70	1
17	Seat retaining	Stainless St. ASTM A351 CF8M	1
18	Ring	Carbon St., WCB	1
19	Body bolt	Stainless St. ISO 4014 A2-70 Carbon St. ISO 4014 GR 8.8 zinc plated	8
20	Body nut	Stainless St. ISO 4032 A4-70	8
21	Tag	Stainless St. ASTM A167 304	1
22	Disc spring	Stainless St. ASTM A693 17-7PH	2
23	Tab washer	Stainless St. ASTM A240 304	1
24	Stem nut	Carbon St. Zinc Plated	1

# Valves Dimensions 3"- 8"

## Stainless Steel

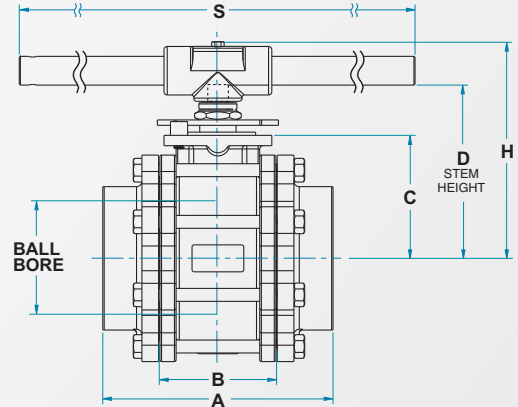
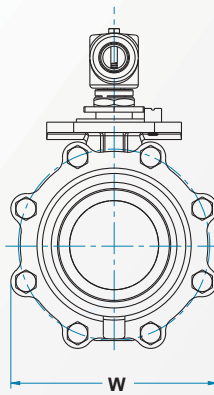
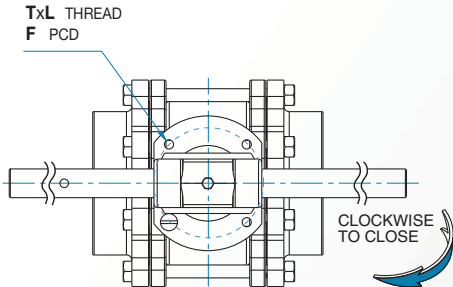

## Carbon Steel

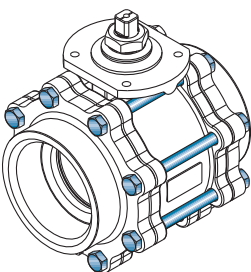
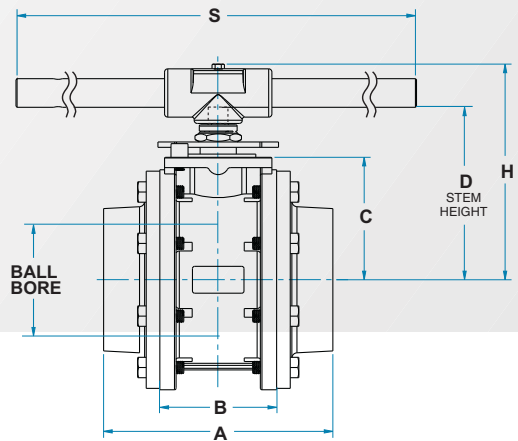
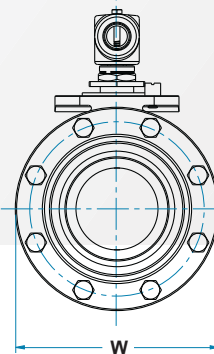
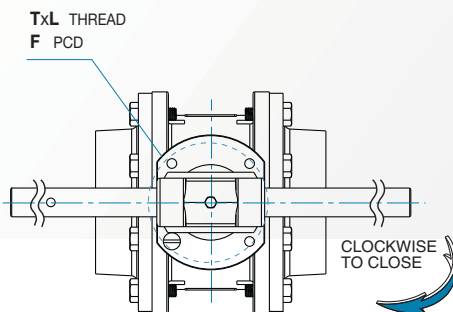

Stainless Steel Valves have thru bolts & nuts

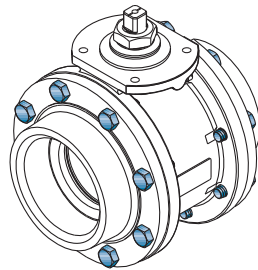

Carbon Steel Valves have threaded bolts

### STEM DIMENSIONS

DD

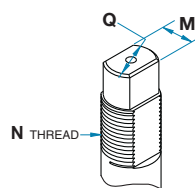

SQUARE

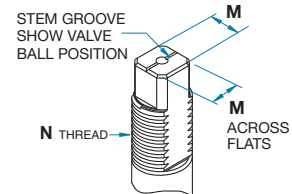

### PREPARATION FOR ACTUATION

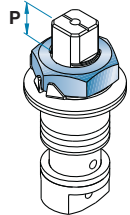

RB	FB	Bore	A R/B	A F/B	B	C	D	H	S	W	M	M-DD	N	P	Q	TxL	F (ISO)	Weight
3"	2 1/2"	63.5	169.0	169.0	83.3	98.3	144.9	185.0	400.0	140.0	18.9	15.9	1"-14	16.7	22.7	M10x20	F10	13.7 Kg
		2.50	6.653	6.653	3.280	3.870	5.705	7.287	15.75	5.500	0.744	0.626	UNS -2A	0.657	0.894	-	102.0	30.3 lb
4"	3"	82.6	214.0	214.0	108.8	114.1	160.7	200.0	600.0	177.0	18.9	15.9	1"-14	16.7	22.7	M10x20	F10	23.7 Kg
		3.25	8.425	8.425	4.283	4.492	6.327	7.894	23.62	6.969	0.744	0.626	UNS -2A	0.657	0.894	-	102.0	52.4 lb
4"	4"	100.0	-	239.0	123.0	124.0	170.5	211.0	600.0	217.0	18.9	15.9	1"-14	16.7	22.7	M10x20	F10	30.0 Kg
		3.94	-	9.409	4.843	4.882	6.713	8.299	23.62	8.543	0.744	0.626	UNS -2A	0.657	0.894	-	102.0	66.3 lb
6"	6"	111.1	283.0	-	146.0	157.0	226.0	286.0	916.0	266.0	28.45	23.75	1 1/2"-12	26.2	35.2	M12x20	F12	63.0 Kg
		4.374	11.142	-	5.748	6.181	8.898	11.260	36.063	10.472	1.118	0.935	UNF -1A	1.031	1.368	-	125.0	138.9 lb

8" Valve dimensions will be given on request

# THREE PIECE BALL VALVES

## ISO 9001:2008 Certified

As an ISO 9001:2008 certified company, Habonim operates according to internal manufacturing specifications written for each application and for specific customers. From material procurement to final inspection of assembled valves, Habonim controls its procedures for the integrity of the parts, their manufacturing process, storing and preservation and final assembly, to keep the highest standards of perfection of the product.

## Standards of Compliance

Design:	ANSI B16.34 BS 5351, BS 5159
Threaded End Connections:	NPT ANSI B1.20.1 BSPT ISO R/7, BS 21 BSP ISO R/7, BS 2779 DIN 2999, DIN 3852
Socket Weld End Connections:	BS 1600, API 5L, ANSI B16.11, DIN 3239/Pt 2
Buttweld End Connections: (Schedules 5, 10, 40, 80)	API 5L, BS 1600 ANSI B16.25, DIN 3239/Pt 1
Pressure Testing:	API 598, ISO 5208 EN 12266-1:2003
Fire Testing:	API 607 4th Edt. API 6FA EN 12266-1:2003
NACE (must be specified):	MR-0175
Quality Assurance:	ISO 9001-2008
Certification:	PED 97/23/EC Module H ATEX Directive 94/9/EC

## In-Line Maintenance

The 47P and 46 series 3-piece ball valves are in-line repairable, thus reducing on maintenance time and cost when servicing the valves. This also allows quick and easy replacement of the valve trim or upgrading for new applications without loss of downtime. Prior to servicing the valve, bring it to the open position making sure to release line pressure and drain all trapped media from the valve cavity. Keep the valve in the open position and remove all but one body bolt, so the valve body can swing away from its installed position and be brought out of the pipe line. In this position it is easy to replace all internal parts and then swing the body back to its original position.

If it is required to completely remove the body, remove the last bolt and bring out the body center section.

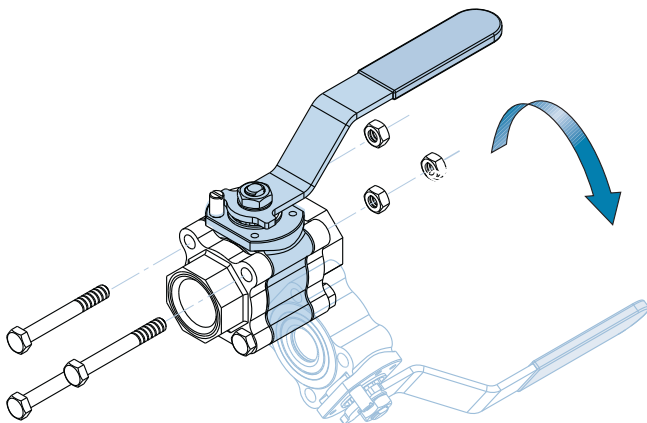

## Assembly, Marking and Packaging

All valves are 100% leak tested before packaging. Each valve is tagged for traceability and material certification will be provided on request. Habonim valves are delivered in the open position and with capped ends. Keep the valve in the open position and remove end caps only prior to installation. Actuated valves are kept in their Fail-Safe position. Use the bolt torque figures according to the tightening patterns shown below for safe operation. It is recommended to flush the pipe line before operating the valve, to prevent seat damage.

Valve Size	Bolt Size	Tightening Torque	
		Nm	in-lb
1/2"-3/4"	M6	10	89
1"-1 1/4"	M8	22	195
1 1/2"-3"	M10	45	400
4"	M12	75	655
6"	M16	161	1425

Valve Size	Cv Values		Limiting Stem Input Torque*					
	RB	FB	Flow Coefficients		316 S/S Stem material		17-4PH Stem material	
			Cv	Kv	Nm	in-lb	Nm	in-lb
1/4"			3	2.6	13.2	117	91	800
3/8"			5	4.3	13.2	117	91	800
1/2"			8	6.9	13.2	117	91	800
3/4"	1/2"		12	10.4	13.2	117	91	800
1"	3/4"		32	28.1	24.4	216	165	1,460
1 1/4"	1"		57	49.3	24.4	216	165	1,460
1 1/2"	1 1/4"		80	69.2	48.6	430	268	2,370
2"	1 1/2"		104	90	48.6	430	268	2,370
2 1/2"	2"		240	208	-	-	268	2,370
3"	2 1/2"		320	277	385	3400	1920	17,000
4"	3"		580	501	385	3400	1920	17,000
	4"		2400	2070	-	-	1920	17,000
6"			820	707	1570	13900	7500	66,300

Cv - Flow in US GPM at 1 psi pressure drop.

Kv - Flow in m<sup>3</sup>/hr at 1 bar pressure drop.

Valve flow rates are determined in full open position with water at 15 C° (60 F°).

\* Limiting Stem torque figures are based on random laboratory tests.

These are not to be confused with valve operating torque.

## Actuated Valves

Where automation is required, the 47P series ball valves are available with Habonim's unique 4-Piston pneumatic Compact actuator. The Compact actuator is available in 8 sizes, spring return or double acting. All sizes have NAMUR air connections for attaching solenoids. Limit switches and positioners can be mounted on the actuator top face according to or VDI/VDE 3845. Please refer to Bulletin B-360.

## Valve Actuator Sizing

Valve Sizing Tables of the Compact actuators on Habonim Valves are available on request. The sizing table is based on the line pressure, valve seats, working temperature and other factors. The valve torque figures are calculated from tests using water at room temperature at different pressure drops for each seat material and actuator air pressure.

Please contact HABONIM for more details.

## 47P Series Automated Valves Dimensions

### 1/2"- 2 1/2" 47P series

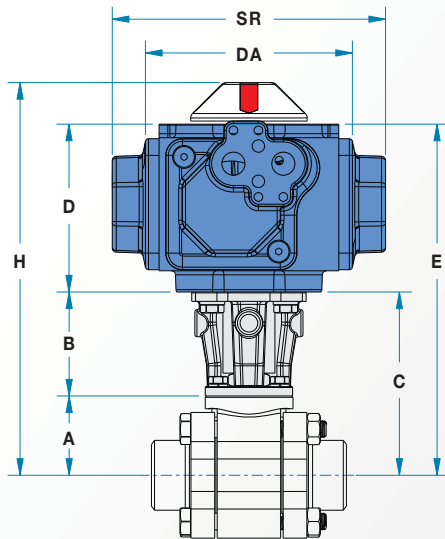

### 3"- 4" 47P series

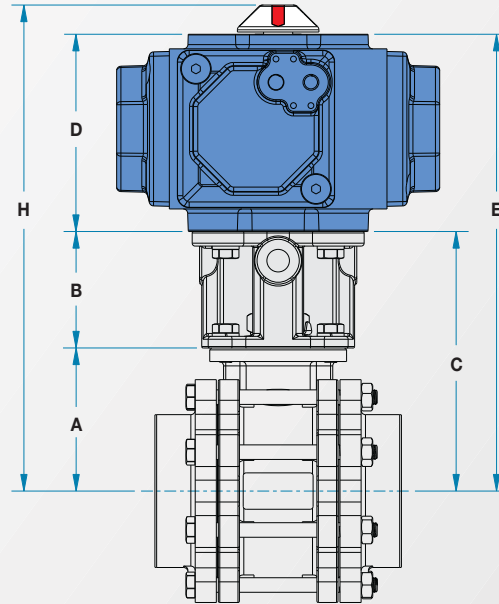

Valve Size	Actuator size	47P Series					Compact Actuator		
		A	B	C	E	H	D	DA	SR
1/2" F03	C15	1.142	1.575	2.717	5.433	6.220	2.717	3.386	4.331
	C20		1.575	2.717	5.894	6.681	3.177	4.016	5.157
	C25		1.575	2.717	6.543	7.331	3.827	5.197	6.339
3/4" F03	C15	1.236	1.575	2.811	5.528	6.315	2.717	3.386	4.331
	C20		1.575	2.811	5.988	6.776	3.177	4.016	5.157
	C25		1.575	2.811	6.638	7.425	3.827	5.197	6.339
1" F04	C15	1.504	1.969	3.472	6.189	6.976	2.717	3.386	4.331
	C20		1.969	3.472	6.650	7.437	3.177	4.016	5.157
	C25		1.969	3.472	7.299	8.087	3.827	5.197	6.339
	C30		1.969	3.472	8.063	8.850	4.591	5.945	7.323
1 1/4" F04	C15	1.677	1.969	3.646	6.362	7.150	2.717	3.386	4.331
	C20		1.969	3.646	6.823	7.610	3.177	4.016	5.157
	C25		1.969	3.646	7.472	8.260	3.827	5.197	6.339
1 1/2" F05	C30	1.717	1.969	3.646	8.236	9.024	4.591	5.945	7.323
	C20		2.362	4.079	7.256	8.043	3.177	4.016	5.157
	C25		2.362	4.079	7.906	8.693	3.827	5.197	6.339
2" F05	C30	1.902	2.362	4.079	8.669	9.457	4.591	5.945	7.323
	C35		2.362	4.079	9.413	10.201	5.335	7.165	8.740
	C20		2.362	4.264	7.441	8.228	3.177	4.016	5.157
	C25		2.362	4.264	8.091	8.878	3.827	5.197	6.339
2 1/2" F07	C30	2.756	2.362	4.264	8.854	9.642	4.591	5.945	7.323
	C35		2.362	4.264	9.598	10.386	5.335	7.165	8.740
	C45		2.362	5.118	8.945	9.732	3.827	5.197	6.339
	C20		2.362	5.118	9.709	10.496	4.591	5.945	7.323
3" F10	C35	3.870	2.362	5.118	10.453	11.240	5.335	7.165	8.740
	C45		2.362	5.118	11.575	12.362	6.457	8.701	10.591
	C60		3.150	7.020	11.610	12.398	4.591	5.945	7.323
	C75		3.150	7.020	12.354	13.142	5.335	7.165	8.740
4" F10	C45	4.492	3.150	7.020	13.476	14.264	6.457	8.701	10.591
	C60		3.150	7.020	15.583	16.764	8.563	11.220	14.173
	C75		3.150	7.020	17.650	18.831	10.630	13.465	17.205
	C35		3.150	7.642	12.976	13.764	5.335	7.165	8.740
4" FB F10	C45	4.854	3.150	7.642	14.098	14.886	6.457	8.701	10.591
	C60		3.150	7.642	16.205	17.386	8.563	11.220	14.173
	C75		3.150	7.642	18.272	19.453	10.630	13.465	17.205
	C35		3.150	8.004	13.339	14.126	5.335	7.165	8.740
4" FB F10	C45	4.854	3.150	8.004	14.461	15.248	6.457	8.701	10.591
	C60		3.150	8.004	16.567	17.748	8.563	11.220	14.173
	C75		3.150	8.004	18.634	19.815	10.630	13.465	17.205

All dimensions are for reduce bore valve sizes. For full bore valve size dimension up to 3", use a "one size-up" valve.

# THREE PIECE BALL VALVES

47P/46 Series

## How to order The HABONIM 47P/46 Ball Valve Identification Code

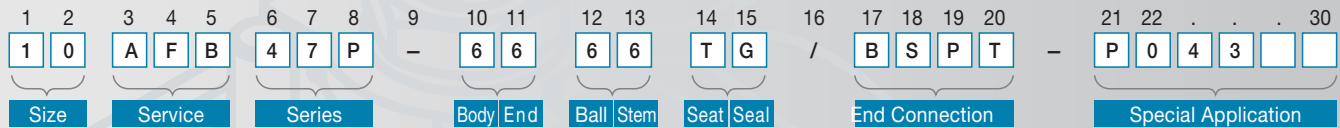

46  
47P

Size			Service		Body / End Ball / Stem		Seat		Seal		End Connection	
Code	inch	mm	A	B	1	4	A	B	B	BSPT	BS 21	
02	1/4"	8	A Antistatic	B Full bore	1 Bronze	4 Carbon Steel	A TFM	C PCTFE	B Buna "N"	DIN	DIN 2999 (BSPP)	
03	3/8"	10	C Cryogenic	D Diverter bottom entry	5 Brass	5 Brass	F PFA	E EPDM (EPR)	Shore 90	NPT	B1.20.1	
05	1/2"	15	H High pressure	F Firesafe	6 S. St. 316 (L)	6 S. St. 316 (L)	H VX1	G Expanded Graphite	Graphite	BW	Buttweld	
07	3/4"	20	I High purity	H High purity	7 Monel	7 Monel	J 25% Glass filled PTFE	I Impregnated Graphite	Graphite	Sch	Sch 5, 10, 40, 80	
10	1"	25	K Dry Chlorine	L Let Lok	8 S. St. 304	8 S. St. 304	K Carbon filled PEEK	J 25% Glass filled PTFE	Graphite	XBW	Extended Buttweld	
12	1 1/4"	32	N Control	O Oxygen	9 C. Steel LCB	9 C. Steel LCB	L Virgin PEEK	K Kalrez®	Graphite	SW	Socketweld	
15	1 1/2"	40	Q Cavity filler	R Bottom tank	A Alloy-20	A Alloy-20	M Metal	M PTFE coated S. St O-Ring	Graphite	XSW	Extended Socket Weld	
20	2"	50	S Diverter side entry	V Vacuum	C Hasteloy-C	C Hasteloy-C	P NRG	N Neoprene	Graphite	BWO	OD tube	
25	2 1/2"	65	T Titanium Gr.2	W Steam & Thermal Fluid	D Duplex	D Duplex	R 15% Glass filled PTFE	R 15% Glass filled PTFE	Graphite	ETO	Extended OD tube	
30	3"	80	X Metal seat		E S. St. 317L	E S. St. 317L	S VESPEL	T PTFE	Graphite	SWO	Socketweld OD tube	
40	4"	100			F C. Steel LF2	F C. Steel LF2	T PTFE	U UHMWPE	Graphite	TC	Tri-Clamp	
60	6"	150			I Inconel 625	I Inconel 625	U UHMWPE	V Viton®	Graphite	KLM	Copper tube brazing	
80	8"	200			L AL6XN	L AL6XN	Y Acetal Resin Derlin®		Graphite	ETB	Extended Copper tube	
					K Super Duplex	K Super Duplex			Graphite	LL	Let Lok (Inch)	
					M 17-4PH	M 17-4PH			Graphite	LM	Let Lok (Metric)	
					S SMO254	S SMO254			Graphite	PN40	Flanged DIN PN40	
					T Titanium Gr.2	T Titanium Gr.2			Graphite			
					W Hasteloy-C22	W Hasteloy-C22			Graphite			
					Z Inconel 718	Z Inconel 718			Graphite			

Other end connections are available on request.

Special Application	
A0866	Stem seal Ammoniaservice
P043	Stem seal for vacuum and gas service
F043	Stem seal Neoprene for Freon Service
P250	Ball with Pressure relief hole
J2N05	Jacketed valve, No. of Outlets, Type, Size
FE	Fugitive Emission
V60	Control valve seat
VB30	Control V Ball
DBB	Double Block & Bleed
NACE	Nace service
K	LLP Locking device
EP	Electro Polish
G18	Grit 180 Internal finish
G24	Grit 240 Internal finish
G32	Grit 320 Internal finish
HC	High Cycle stem arrangement
SRS	Self Relieving Seat
DHN	DHN coating
WR	DD Stem

## How to order

When placing an order for HABONIM valves, please provide as many details possible on the application such as: Media, Temperature, Pressure, Pipe line size and type of connection.

### Example A: 10 AFB47P - 4466TG / BW

Size 1" (10), Antistatic (A), Firesafe (F), Fullbore (B), 3-piece (47P), C. St Body & Ends (4), S. St 316 Trim (6), PTFE Seats (T), Graphite Body Seals (G), Buttweld ends (BW)

### Example B: 20 R47P - 666MKV / PN40-FT

Size 2" (20), Tank Bottom (R), 3-piece ISO (47P), S. St 316 Body, End & Ball (6), S.St. 17-4PH Stem (M), PEEK Seats (K), Viton Body Seals (V), DIN Flanged end (PN40), Flush Tank end (FT)

DELTRIN® is a registered trademark of DuPont, VESPEL® is a registered trademark of DuPont, KEL-F® is a registered trademark of 3M Company  
 NYLATRON® is a registered trademark of Quadrant DSM Engineering Plastic Products, TFM™ is a trademark of Dyneon, PEEK® is a trademark of VICTREX  
 In accordance with our policy to strive for continuous improvement of the product, we reserve the right to alter the dimensions, technical data and information included in this catalogue when required.  
 Copyright © 2009 HABONIM Ltd. All rights reserved



**Headquarters Habonim ISRAEL**  
 Tel: +972-4-6914911, Fax: +972-4-6914902  
 sales\_international@habonim.com

**ISRAEL**  
 Tel: +972-4-6914903  
 Fax: +972-4-6914935  
 sales\_israel@habonim.com

[www.habonim.com](http://www.habonim.com)

**North America**  
 Toll Free Phone: 1-866-261-8400  
 Toll Free Fax: 1-866-243-9959  
 sales\_usa@habonim.com

**Europe**  
 Habonim Europe  
 Tel: +972-4-6914733  
 Fax: +972-4-6914703  
 sales\_europe@habonim.com

**U.K.**  
 Habonim UK  
 Tel: +44-1633-484554  
 Fax: +44-1633-482252  
 sales@habonimuk.com

**China**  
 Habonim China  
 Tel: + 86 21 5219 1139  
 Fax: + 86 21 5219 3780  
 sales\_china@habonim.com.cn

CAT47PP-1111 10/09

