

INCH



FUGITIVE EMISSION SOLUTIONS

HEALTH & SAFETY SERIES



 **HABONIM**
Industrial Valves & Actuators

DEDICATED TO INNOVATION



Background

Industry is making major contributions towards improving our global environment by reducing hazardous emissions, reducing product losses and addressing environmental concerns. Since the advent of the "Clean Air Act Amendment" of 1990 (CAAA), introduced by the U.S. Environmental Protection Agency (EPA), industrial plants have revised their specifications regarding fugitive emissions.

The Challenge

Eliminating product emissions is one of the most serious challenges for process industry and consequently can be most costly to control. As part of its Health & Safety initiative campaign Habonim has introduced additional Security to the valve stem design for critical applications.

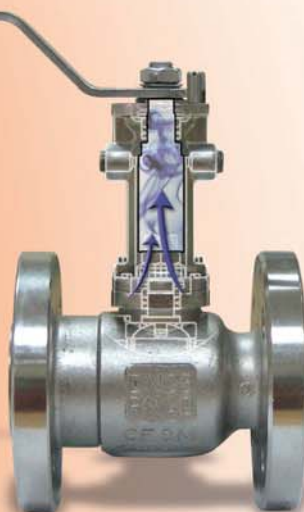

Design features

- Modular design uses a double defence sealing concept. The first defence line is based on the valve stem seal arrangement, while the second line is integral with the F.E. bonnet.
- A machined lip on the bonnet bottom plane will ensure a safe fit over the valve ISO pad. A static seal will provide security to the atmosphere.
- The bonnet design allows a sensing device to be fitted between the two sealing arrangements, In case of first defence line failure an alert can be immediately identified.
- Any media is contained within the F.E. bonnet until valve maintenance can be safely held.
- Double blowout proof stems.
- Linear alignment between valve stem, extension and actuator to reduce side load.
- Rigid construction.
- Precision stem and packing bore finish.
- Fire-safe valve stem packing and valve connection to bonnet (upon request)
- Stainless steel cast CF8M housing material as standard.
- Exotic materials Alloy-20, Hasteloy-C22, Monel and more (upon request).
- Various solutions are offered by Habonim when sizing F.E. bonnets to customer applications: HC (high cycle), N (Control valves), KG (fire-safe and thermal applications), and the HermetiX™ Habonim patented stem packing.

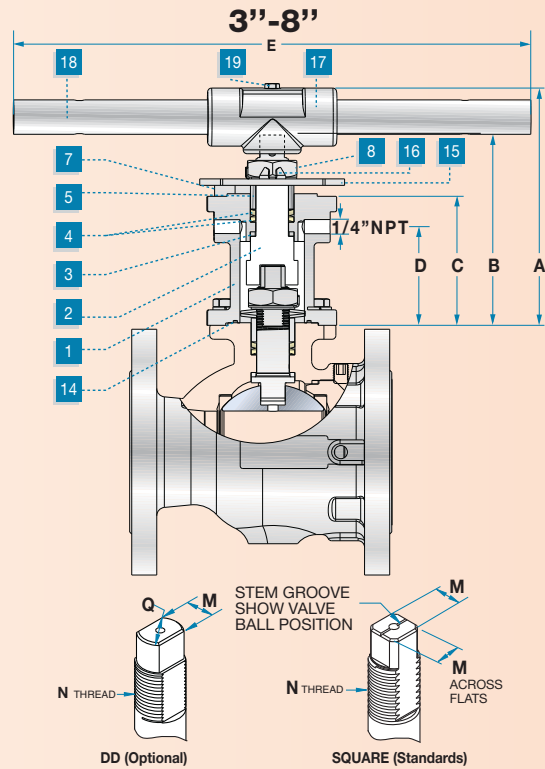
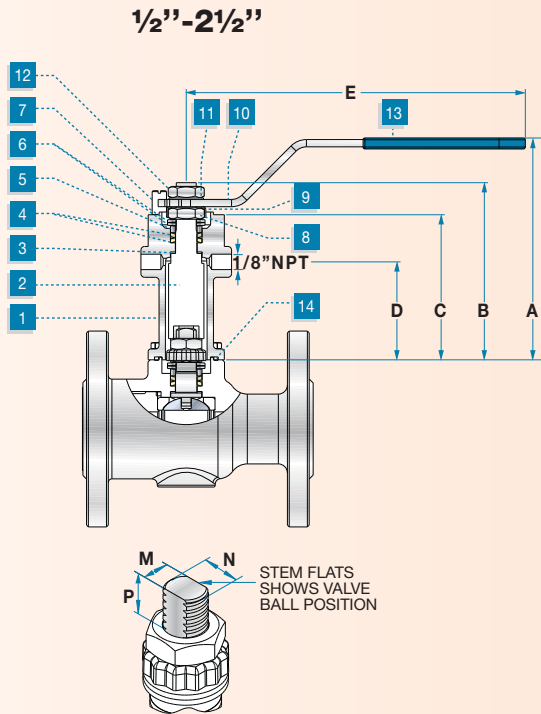

1/2''-8''

Item	Description	Material	Qty
1	Body	SS ASTM A351 CF8M	1
2	Stem	SS ASTM A276 316/316L	1
3	Stem Thrust Seal	CARBON FILLED PTFE	1
4	HermetiX™ Seal	CARBON FILLED PTFE	1
5	Follower	SS ASTM A276 316/316L	1
6	Disc Spring	SS 17-7PH	2
7	Stop Pin	SS ASTM A582 303	1
8	Stem Nut	SS ASTM A194 316	1
9	Locking Clip	SS ASTM A164 304	1
10	Handle	SS ASTM A240 430	1

Item	Description	Material	Qty
11	Serrated Washer	SS 410	1
12	Handle Nut	SS ASTM A194 316	1
13	Handle Sleeve	VINYL PLASTISOL	1
14	Bonnet Seal	PTFE / GRAPHITE	1
15	Stop Plate	SS ASTM A240 430	1
16	Tab Lock Washer	SS ASTM A240 304	1
17	Wrench Head	ASTM A47 MALEABLE IRON	1
18	Wrench Handle	SS 304	1
19	Wrench Handle Bolt	SS ISO 4014 A2-70	1

Dimensions (mm)

Reduced port Valve size		FE size	A	B	C	D	E	M	N	P	ISO
1/2" & 3/4"	mm	05	114	89.1	80	55.25	150	5.5	3/8" UNF	7.2	F03
	inch		4.488	3.508	3.150	2.175	5.906	0.217		0.283	
1" & 1 1/4"	mm	10	122	97.4	80	54	187	7.54	7/16" UNF	7.2	F04
	inch		4.803	3.835	3.150	2.126	7.362	0.297		0.283	
1 1/2" & 2"	mm	15	154	129.4	100	77	236	8.71	9/16" UNF	8	F05
	inch		6.063	5.094	3.937	3.031	9.291	0.343		0.315	
2 1/2"	mm	25	144	118.1	100	76.5	236	8.71	9/16" UNF	13.5	F07
	inch		5.669	4.650	3.937	3.012	9.291	0.343		0.531	
3" & 4"	mm	30	187	196.6	150	76.5	401	18.9	1" UNS	16.7	F10
	inch		7.362	7.740	5.906	3.012	15.787	0.744		0.657	
6" & 8"	mm	60	273	219	150	100	916	28.45	1 1/2" UNF	26.2	F12
	inch		10.748	8.622	5.906	3.937	36.063	1.120		1.031	

F.E. Stem operating torque

Reduced port Valve size	FE size	HC / HermetiX™		Al packing		Control valves (N) / Graphite packing (KG)	
		N*m	lbf*inch	N*m	lbf*inch	N*m	lbf*inch
1/2" & 3/4"	05	2	17.7	3	26.5	4	35.4
1" & 1 1/4"	10	5	44.2	7	62	9	79.6
1 1/2" & 2"	15	7	62	11	97.3	13	115
2 1/2"	25	7	62	11	97.3	13	115
3" & 4"	30	13	115	18	159.3	25	221.2
6" & 8"	60	32	283	43	380.5	60	531

DD Dimensions

Reduced port Valve size		M	Q
3" & 4"	mm	15.9	22.7
	inch	0.626	0.894
6" & 8"	mm	23.75	35.2
	inch	0.935	1.368

Note: When sizing an actuator add the above figures to the valve operating torque

FUGITIVE EMISSION SOLUTIONS

HEALTH & SAFETY SERIES

Additional Options

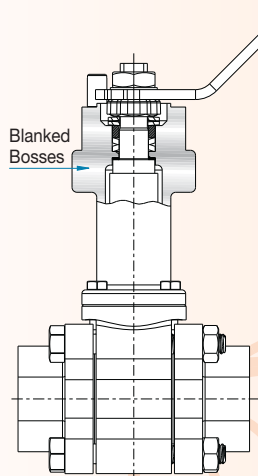

Media Containment Unit (MCU)

Suitable for critical applications when:

- Valve stem maintenance needs to be programmed.
- A combination of high temperature and high cycle conditions.
- Valve is in low temperature applications. (down to $-70\text{ }^{\circ}\text{C}$ / $-57\text{ }^{\circ}\text{F}$)



Caution!

MCU is not to be used with toxic media

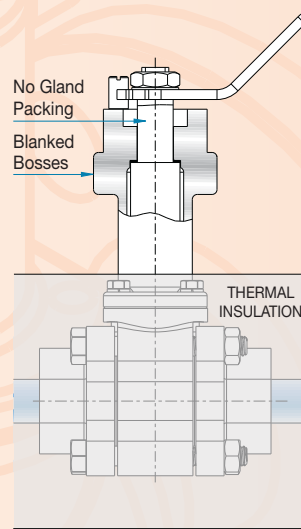

Extended Bonnet (EXT)

- When valve and pipe lines need to be insulated.
- When valve operation must be elevated from extreme temperature areas.
- When direct mounting of actuator to a valve is not suitable.

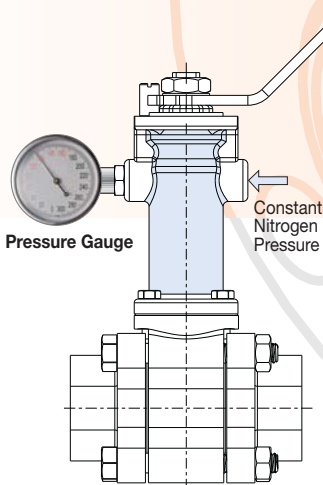

Pressure Box Sealing

A special F.E. bonnet was designed for a fire safe, high cycle operation within a highly aggressive and explosive application. The chamber between the two seals was pressurized with inert gas, which eliminates the presence of oxygen inside the FE bonnet and the risk of explosive conditions.

Constant pressure of inert gas, 10 psi above the line pressure, eliminated any possible stem leak of the aggressive media. A pressure gauge connected to one of the FE tapped holes detect any pressure loss which correlates to the valve stem packing condition.



Caution!

Pressure within the bonnet must not exceed 725 psi!

How to order

Fugitive Emission Bonnet (FE)

- **870763xx9** HermetiX™ Habonim patented stem packing.
- **870763xx9-AC** Virgin PTFE Chevron packing
- **870763xx9-N** Control application
- **870763xx9-HC** High cycle
- **870763xx9-KG** Thermal flow

Media Containment Unit (MCU)

- **870764xx9** (suffix adder as per the above 763 F.E. bonnet)

Extended Bonnet (EXT)

- **870769xx9** (No suffix required)

Reduced port Valve size	FE size (xx)
1/2" & 3/4"	05
1" & 1 1/4"	10
1 1/2" & 2"	15
2 1/2"	25
3" & 4"	30
6" & 8"	60

In accordance with our policy to strive for continuous improvement of the product, we reserve the right to alter the dimensions, technical data and information included in this catalogue when required.

Copyright © 2009 HABONIM Ltd. All rights reserved



HABONIM USA

Toll Free Phone: 1-866-261-8400
Toll Free Fax: 1-866-243-9959
sales_usa@habonim.com

HEADQUARTERS HABONIM ISRAEL

Tel: +972-4-6914911
Fax: +972-4-6914902
sales_international@habonim.com

www.habonim.com

CATFEC-7101 10/09

