

INCH

7-Year Warranty*

*See Habonim website for details.

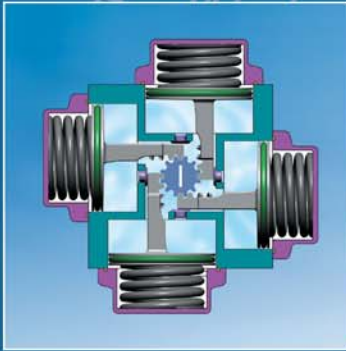

4 PISTON PNEUMATIC ACTUATOR

COMPACT II SERIES



TABLE OF CONTENTS	Page
COMPACT DESIGN	2-3
PRINCIPLE OF OPERATION	4
PARTS LIST	5
MAIN FEATURES	6-7
TORQUE-METRIC	8
TORQUE-IMPERIAL	9
TECHNICAL DATA	10
DIMENSIONS	11
HOW TO ORDER	12

Proven Advantage

The **COMPACT II** is a quarter turn rack & pinion pneumatic actuator that is **patented** worldwide.

The superiority of the **COMPACT II** actuator over single and double rack & pinion actuator designs, results from the four pistons which generate torque around a centrally located pinion, thereby giving more than double the torque achieved by these other designs.

The increased number of pistons in the actuator allows their diameter to be reduced while maintaining its high torque. This also allows the overall size of the actuator to be reduced and become more compact.

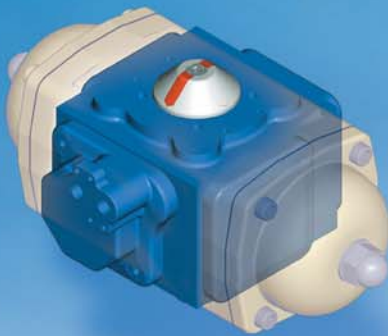

Space Saving, Fast Acting

The **COMPACT II** has four small cylinders, each located on one of the four sides of a cube. At a given air pressure, the **COMPACT II** can produce the same torque output as double piston actuators, using smaller diameter pistons and a narrower pinion. A narrower pinion results in a shorter piston travel, which permits a compact, space saving mechanism and fast acting travel from one position to the next.



Superior Corrosion Resistance

The body and covers are anodized internally and externally, providing protection against ingress of corrosive atmosphere.

An external epoxy base layer and a second polyurethane paint provides additional protection against aggressive environments. Optional Electroless Nickel Coating of body, covers and stop.



Less Air Consumption

The **COMPACT II** gives maximum torque for minimum air consumption. It is both compact in size and energy efficient, creating a fast-responding, trouble-free, high cycle lifespan.

The cube shape of the **COMPACT II** and the short piston travel serve to minimize excess space. This is space which is not swept by piston travel and which must be pressurized before the piston motion begins; therefore, reducing the pressurization of excess space and resulting in reduced energy requirements.

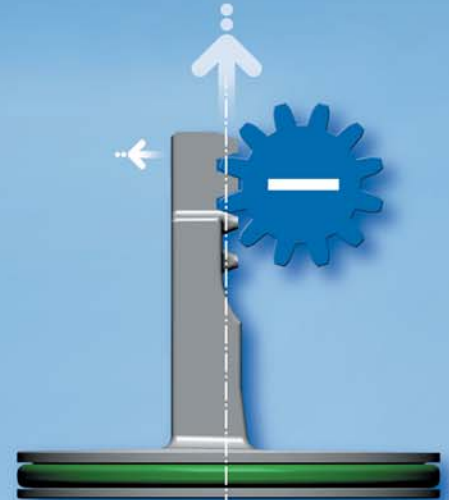

Balanced Forces

The cube-shaped configuration of the **COMPACT II** positions the pistons so that each piston develops thrust along its own axis, rather than the off-axis thrust, that results from the geometry of most other actuator configurations. Piston side loading, caused by off-axis thrust, does not occur, thus resulting in less stress on the seals.

Nested Springs

The **COMPACT II** four-spring chambers can use up to three different spring sizes, which are nested between the covers and pistons and are aligned by centering rings. Each spring is wound in the opposite direction to its neighbor to avoid entanglement. As there are four cylinders, there are many more spring combination possibilities than with double piston actuators. This results in better solutions for any air supply pressure required. Special painting of the springs provides higher corrosion resistance to the environment, giving more than 250 hours of life in a salt spray bath.

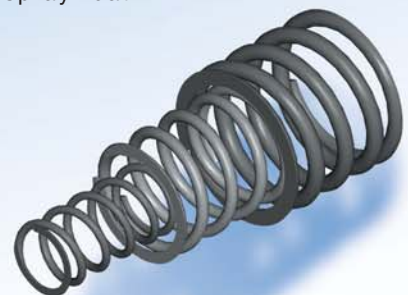

Less Wear

With its unique 4-piston design, the Compact II achieves a more uniform load distribution than do single and double piston actuators, therefore greatly reducing gear wear at the points of contact between rack and pinion.

The force-balanced piston with its shorter stroke prevents uneven wear of O-rings, gear and pistons. This eliminates the need for bearings and reduces the number of soft parts, thereby resulting in longer maintenance schedules and low cost of repair kits. The high surface finish of the four cylinder is protected from wear due to the hardened surface created by the anodizing treatment.

Indicator & Puck



A highly visible indicator with flow direction arrows is snapped to the pinion providing easy identification of valve position. The indicator snap-on arrows allow true positioning of any type of ball porting. A puck with three position signaling inserts and a highly visible indicator with flow direction arrows is bolted to the pinion to provide a cost effective option for valve monitoring.

Pinion

The pinion has a double-square female drive on its bottom plane for accepting the ISO 5211 or DIN 3337 coupling options. The top plane has the Namur slot for attachment to switches or positioners. There is a machined flat below the Namur interface to provide for manual operation of the actuator by use of a wrench. The pinion is made from carbon steel with EN plating which gives a hard wearing surface with added protection against corrosive environments.

Limit Stop

The pinion and stop rotation can be adjusted by four large diameter adjustable set screws diametrically opposed and threaded into the actuator body. Each opposing pair of screws exerts simultaneous and equal forces on opposite sides of the stop when the rotation limit is reached, thus, no off-center forces are generated.

The stop design allows for $\pm 5^\circ$ of rotational adjustment in both directions of travel.

Any intermediate position can be achieved with a longer set of stop screws. This feature is built into the actuator stop mechanism and eliminates the need for additional plates and screws.

The stop material is St.St. for better wear and corrosion resistance.

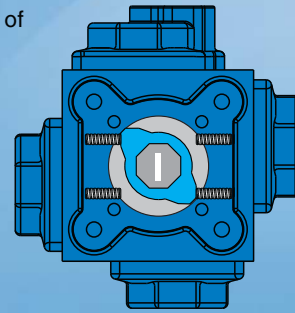
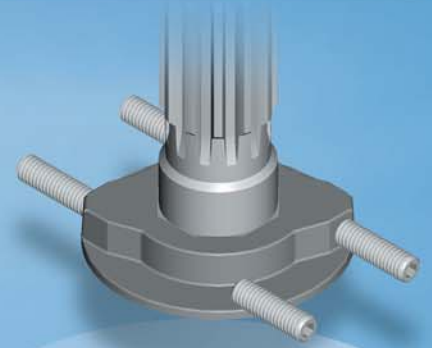

Close

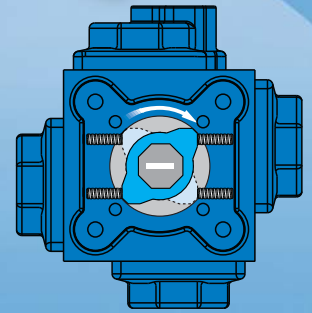

Open

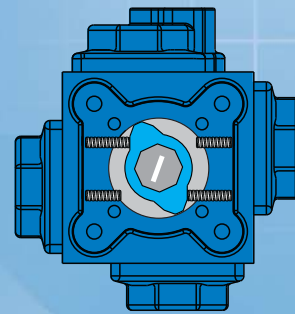

Limit

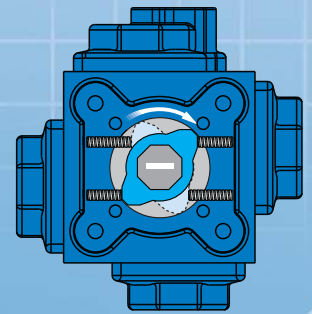

Open





The **COMPACT II** actuator transforms the linear motion of its pneumatic pistons into rotary motion via 4 gear racks that drive the central pinion. Air Supply, to drive the pistons, flows into port **A** of the NAMUR cover: Port **A** is connected to the center chamber and port **B** is connected to the four outside chambers.

Double Acting

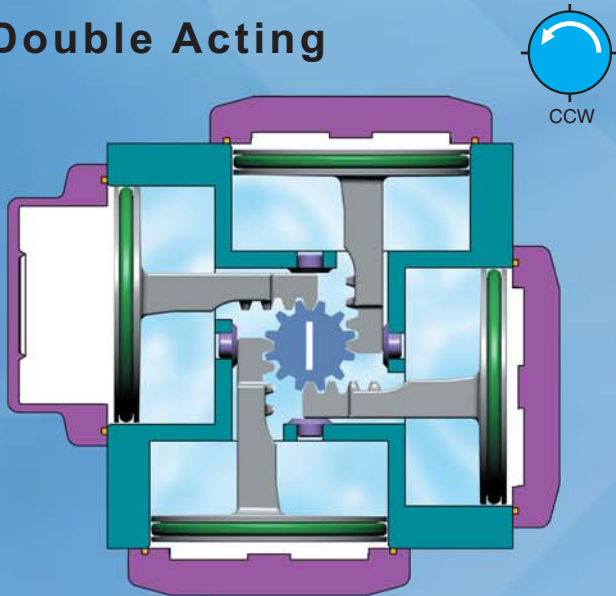

Pressure entering Port A to open:
 Center chamber pressurized. Pistons move outward.
 Pinion rotates counter clockwise.

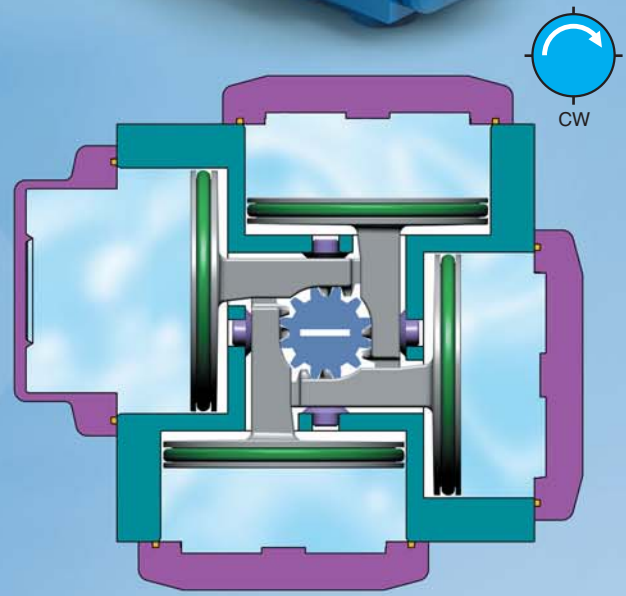

Pressure entering Port B to close:
 Outside chambers pressurized. Pistons move inward.
 Pinion rotates clockwise.

Spring Return

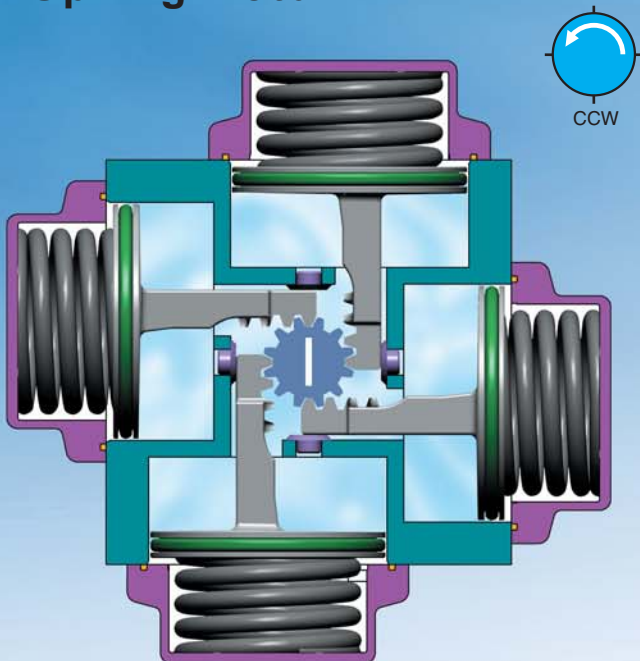

Pressure entering Port A to open:
 Center chamber pressurized. Pistons move outward. Springs are compressed. Pinion rotates counter clockwise.

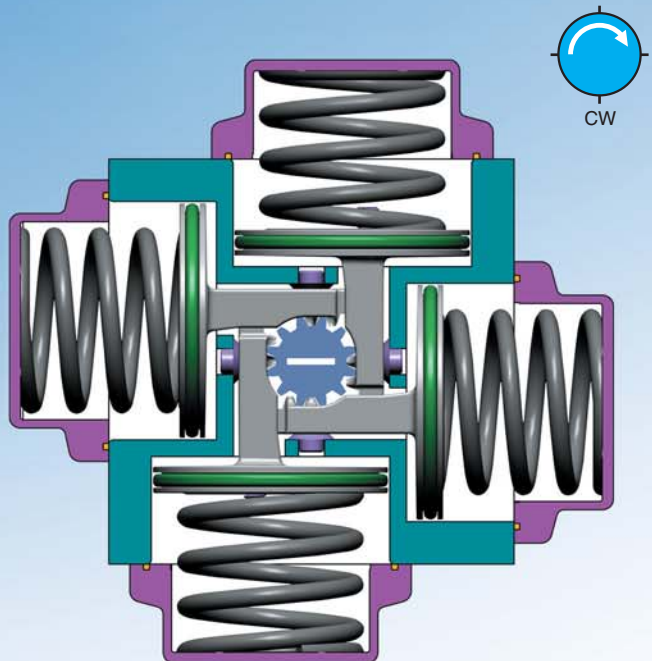

Pressure exiting Port A to close:
 Air released from center chamber. Springs drive pistons inward. Pinion rotates clockwise.

Parts List

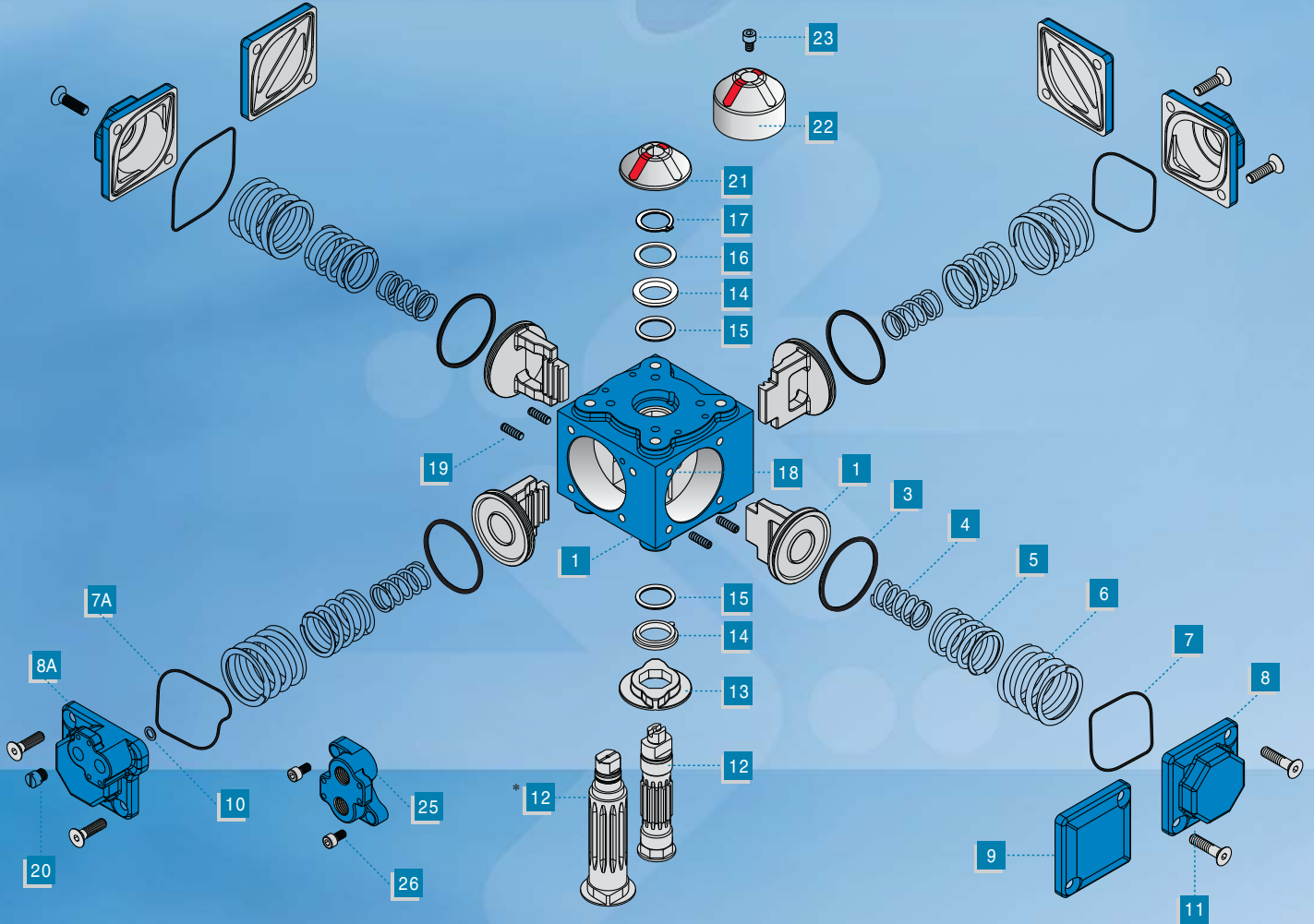

	Description	Qty	Material
1	Body	1	AL 356-T6
2	Piston	4	AL 356/380
3	Piston O-Ring	4	Buna N, Viton, EPDM
4	Inner Spring	4	Spring steel, Painted
5	Middle Spring	4	Spring steel, Painted
6	Outer Spring	4	Spring steel, Painted
7	Cover O-Ring	3	Buna N, Viton, EPDM
7a	Namur Cover O-Ring	1	Buna N, Viton, EPDM
8	Spring Return Cover	3	AL 356/380
8a	Namur Cover	1	AL 356/380
9	Double Acting Cover	3	AL 356/380
10	Air Supply O-Ring	1	Buna N, Viton, EPDM
11	Cover Screw	8-16	ST. ST.
12	Pinion	1	Steel E.N.Coated

	Description	Qty	Material
13	Stop	1	ST.ST 316
14	Thrust Washer	2	Delrin, NRG, UHMWPE
15	Pinion O-Ring	2	Buna N, Viton, EPDM
16	Disc Bearing	1	ST.ST / Delrin
17	Circlip	1	Zink Coated
18	Pad	4	Delrin, NRG, UHMWPE
19	Stroke Adjustment Screw	4	ST. ST.
20	Exhaust Plug (Silencer)	1	Delrin, (Brass)
21	Indicator	1	Plastic (ABS), Red & White
22	Puck	1	Plastic (ABS), Red & White
23	Indicator Screw	1	ST.ST
24	Tag (not shown)	4	ST.ST
25	Namur insert	1	AL 380
26	Insert screw	2	ST.ST

*NOTE: C75 PINION (12) & STOP (13) ARE ONE PIECE



NAMUR output drive for limit switches and positioners

Springs painted for protection and fitted coaxially in a chamber have many setting combinations to provide for any operating pressure



NAMUR VDI/VDE3845 connection to limit switches



Smaller in overall size compared to double piston actuators

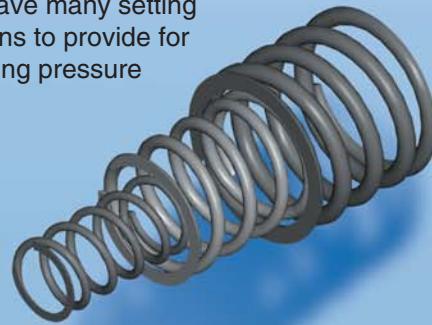

Rugged body construction, anodized and with double layer coating for protection against corrosion

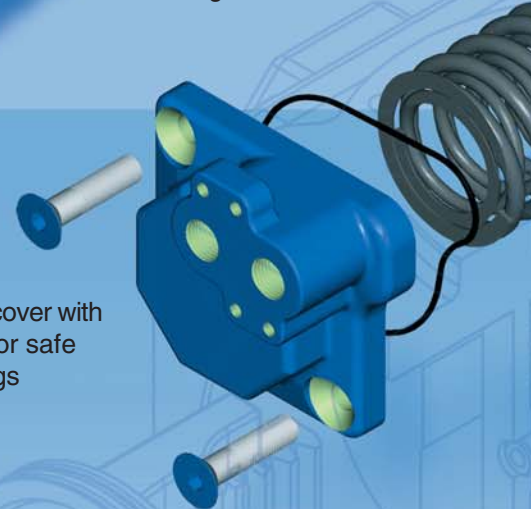

Spring return cover with long screws for safe relief of springs

One cover always with NAMUR interface for solenoid mounting

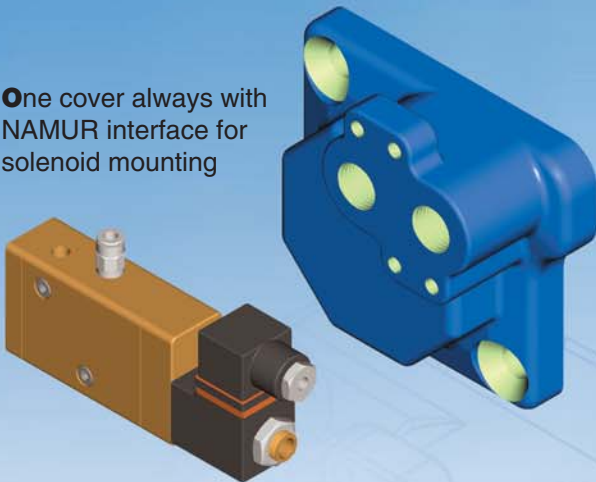

Engineered stop for open-close and intermediate limiting positions

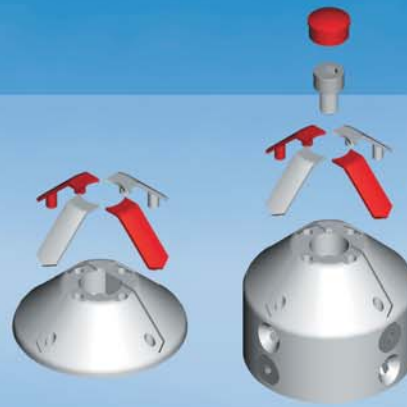

Visible position indicator with coloured arrows and a high profile puck for limit switches

4 pistons symmetrically driving a central pinion with a balanced construction eliminates side loads

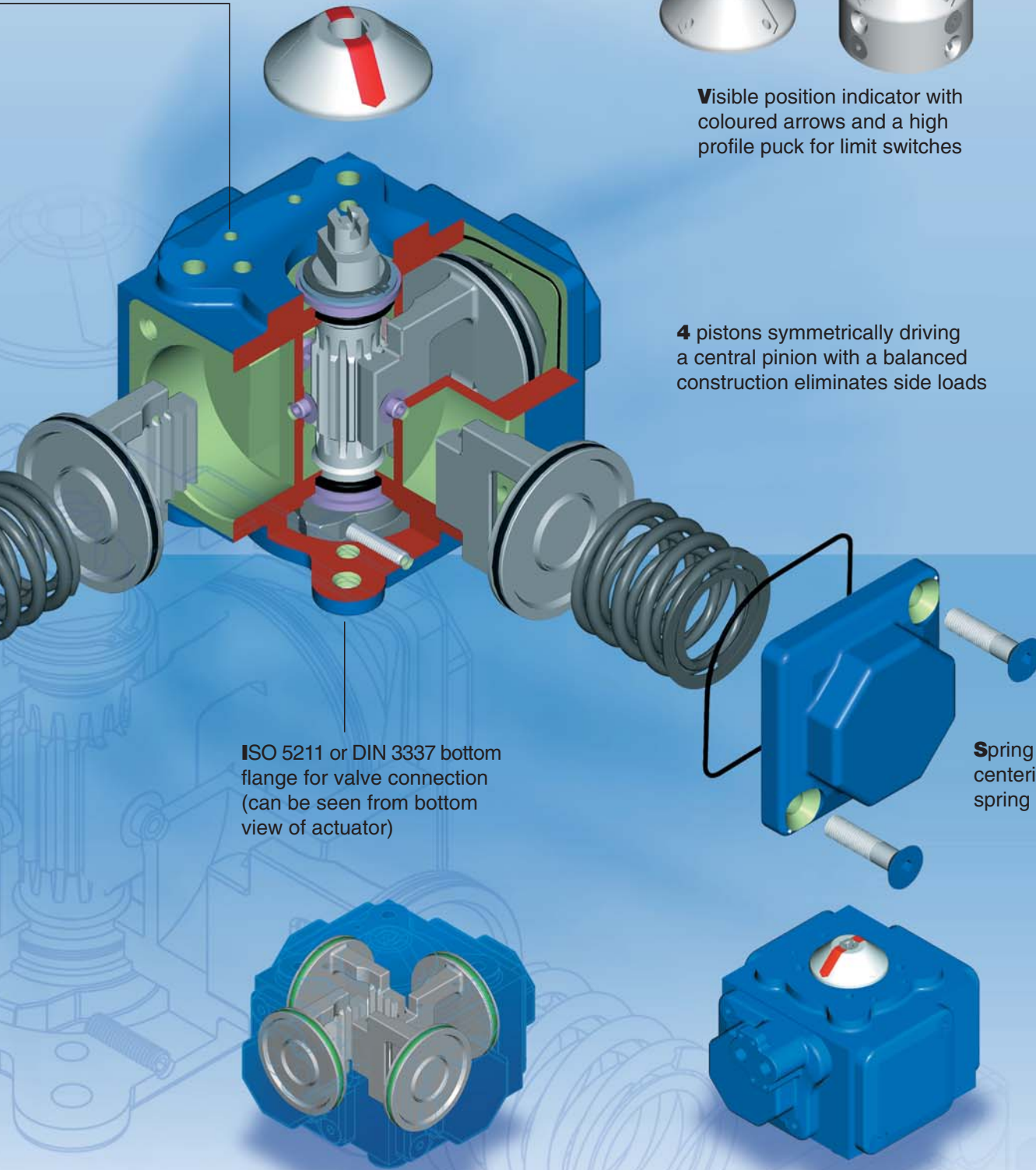

ISO 5211 or DIN 3337 bottom flange for valve connection (can be seen from bottom view of actuator)

Spring covers with centering rings for spring alignment

Patented 4-piston actuator provides double the torque than a dual piston actuator

Compact size with flat covers for double acting applications

Double Acting

SIZE	Operating Pressure (bar)							
	3.0	4.0	5.0	5.5	6.0	7.0	8.0	
C15	10	14	17	19	21	24	27	
C20	18	25	32	35	38	45	51	
C25	39	52	65	72	79	92	105	
C30	62	84	107	119	130	153	176	
C35	114	151	190	208	226	265	304	
C45	222	297	371	408	445	519	593	
C60	527	703	879	967	1,055	1,230	1,406	
C75	974	1,299	1,624	1,786	1,948	2,273	2,596	

TORQUE METRIC CHART (Nm)

Spring Return

Size	Spring set	Air Stroke - bar (psi)														Spring Stroke	
		3.0 (44)		4.0 (58)		5.0 (73)		5.5 (80)		6.0 (87)		7.0 (102)		8.0 (116)			
		Start	End	Start	End	Start	End	Start	End	Start	End	Start	End	Start	End	Start	End
C15	1A	7	4	10	7	13	11	15	12	17	14	20	17	24	21	6	3
	1B			8	4	12	8	13	10	15	11	18	14	22	18	9	5
	1B2					10	5	12	7	13	9	16	11	20	15	12	7
	2									11	6	14	8.5	18	12	15	9
C20	2AB	10	5	17	12	24	18	27	22	30	25	37	31	43	37	12	7
	2A			16	10	22	16	26	19	29	22	35	29	41	35	15	9
	2A2B			14	7	20	13	24	16	27	19	33	26	39	32	18	11
	2B					18	10	22	13	25	17	31	23	38	29	21	13
	2A3					17	9	20	12	23	15	30	22	36	28	22	15
	2C							19	10	22	13	28	19	35	25	25	16
	2C3									21	11	27	17	33	23	27	17
3									19	9	24	15	30	21	29	19	
C25	2AB	25	15	38	27	51	40	58	47	65	53	78	66	90	78	23	13
	2A	23	11	36	23	49	36	55	42	62	49	75	62	88	74	28	16
	2A2B			33	19	46	32	53	39	60	45	73	58	86	70	32	18
	2B					43	27	50	34	57	41	70	53	83	66	36	21
	2A3					41	22	47	29	54	36	67	48	80	61	42	24
	2C					38	18	45	24	52	31	64	44	77	56	47	27
	2C3							43	19	50	25	63	38	75	50	52	29
3									47	21	60	34	73	46	57	31	
C30	2AB	40	26	62	47	84	70	96	81	107	92	130	114	152	136	35	21
	2A	36	19	57	40	80	62	91	73	102	84	125	107	148	129	42	26
	2A2B			52	30	75	52	86	63	98	74	120	96	143	118	53	31
	2B			48	18	70	43	81	54	93	65	115	87	138	109	62	36
	2A3					66	36	77	47	89	58	111	80	134	103	69	40
	2C					64	25	73	39	85	50	107	72	130	94	78	44
	2C3									80	40	102	62	125	85	88	49
3									75	33	98	55	120	77	96	54	
C35	2AB	81	50	118	86	156	123	174	141	192	158	230	195	268	232	62	32
	2A	75	39	111	74	150	112	168	129	186	147	224	184	262	221	74	38
	2A2B	64	26	100	62	139	99	157	117	175	134	213	171	251	208	87	49
	2B			92	44	130	82	148	99	166	117	204	154	242	191	105	58
	2A3					123	67	141	84	159	102	197	139	235	176	121	65
	2C							133	68	151	86	189	123	227	160	137	73
	2C3									143	75	181	112	219	149	149	82
3									135	63	173	100	211	137	161	89	
C45	2AB	148	86	222	158	295	229	331	264	367	300	440	371	513	442	133	72
	2A	134	60	208	132	280	203	317	239	353	275	426	346	499	417	159	86
	2A2B			197	113	269	184	306	219	342	255	415	326	488	397	179	97
	2B			179	82	252	153	288	188	325	224	398	295	471	366	212	115
	2A3					238	127	274	163	311	198	383	269	456	340	239	130
	2C					223	102	260	137	296	173	369	244	442	315	265	144
	2C3									283	147	355	218	428	289	292	158
3									268	122	341	193	414	264	318	173	
C60	2AB	359	216	532	385	706	554	792	639	879	723	1,052	891	1,225	1,060	302	162
	2A	328	160	501	329	675	498	762	583	848	667	1,021	835	1,194	1,004	360	194
	2A2B			478	285	651	454	738	538	824	623	997	791	1,170	960	406	218
	2B			442	221	615	390	702	475	789	559	961	727	1,134	896	473	254
	2A3					580	327	667	411	754	495	926	663	1,099	832	539	290
	2C					548	268	635	352	721	437	894	605	1,067	774	600	323
	2C3									688	378	861	546	1,034	715	661	356
3									657	322	830	490	1,003	659	720	388	
C75	2AB	672	443	992	755	1,312	1,067	1,472	1,223	1,631	1,378	1,951	1,690	2,270	2,000	512	292
	2A	614	345	935	657	1,255	969	1,414	1,124	1,574	1,280	1,894	1,592	2,212	1,902	615	350
	2A2B			891	582	1,211	894	1,370	1,049	1,530	1,205	1,850	1,517	2,168	1,827	693	395
	2B			820	461	1,140	773	1,299	928	1,459	1,084	1,779	1,396	2,097	1,706	819	467
	2A3					1,082	674	1,242	830	1,401	986	1,722	1,298	2,040	1,608	921	525
	2C					1,025	576	1,184	732	1,344	887	1,664	1,199	1,982	1,509	1,024	584
	2C3							1,127	633	1,286	789	1,607	1,101	1,925	1,411	1,126	642
3									1,229	691	1,549	1,003	1,867	1,313	1,229	700	

See Page 10 for Spring Set combinations

Double Acting

SIZE	Operating Pressure (psi)							
	40	60	70	80	90	100	120	
C15	81	125	149	172	188	207	244	
C20	146	229	271	311	351	390	468	
C25	317	476	555	639	723	802	961	
C30	505	769	914	1,052	1,190	1,334	1,611	
C35	928	1,382	1,624	1,848	2,073	2,311	2,780	
C45	1,807	2,719	3,170	3,622	4,074	4,525	5,429	
C60	4,289	6,436	7,511	8,585	9,659	10,725	12,872	
C75	7,926	11,893	13,877	15,856	17,834	19,819	23,767	

TORQUE IMPERIAL CHART (in-lb)

Spring Return

Size	Spring set	Air Stroke - psi (bar)														Spring Stroke	
		40 (2.8)		60 (4.1)		70 (4.8)		80 (5.5)		90 (6.2)		100 (6.9)		120 (8.3)			
		Start	End	Start	End	Start	End	Start	End	Start	End	Start	End	Start	End	Start	End
C15	1A	53	30	91	65	115	91	135	111	156	131	171	147	216	189	53	27
	1B			74	40	99	67	119	86	139	105	155	123	198	161	80	44
	1B2					83	43	102	61	122	80	139	98	180	134	106	62
	2									105	54	123	74	161	106	133	80
C20	2AB	84	43	158	110	204	158	241	192	278	227	320	270	393	339	111	66
	2A			144	88	191	137	227	170	264	205	307	249	380	317	133	80
	2A2B			126	62	174	112	210	145	246	178	289	223	362	291	159	97
	2B					157	88	192	119	228	152	272	198	344	265	186	115
	2A3					144	77	178	109	213	141	258	188	329	253	197	129
	2C							166	85	201	117	246	165	317	229	221	142
	2C3									189	103	235	151	304	215	236	154
C25	2AB	206	121	349	251	435	340	514	413	593	488	676	573	827	716	208	117
	2A			327	212	415	305	492	376	571	450	655	537	805	678	247	139
	2A2B			307	178	396	273	472	343	550	416	636	505	785	644	281	159
	2B					370	235	446	303	523	374	610	465	757	603	322	186
	2A3					347	191	421	258	498	327	586	421	732	556	370	211
	2C							397	217	473	286	562	381	707	514	412	235
	2C3									455	233	545	331	690	462	464	253
C30	2AB	327	214	566	435	722	594	851	715	981	839	1,132	991	1,396	1,243	306	188
	2A	293	155	523	369	682	533	809	652	938	773	1,091	929	1,353	1,178	372	230
	2A2B			478	272	640	443	765	558	893	677	1,048	837	1,308	1,081	469	274
	2B			439	165	598	369	721	482	848	598	1,005	762	1,262	1,002	549	319
	2A3					564	310	687	420	812	534	971	701	1,227	939	613	354
	2C					547	214	651	345	776	457	936	628	1,190	861	690	389
	2C3									729	370	892	545	1,144	774	778	435
C35	2AB	660	408	1,077	784	1,333	1,051	1,544	1,248	1,757	1,447	2,005	1,701	2,453	2,125	547	280
	2A			1,019	681	1,279	956	1,488	1,148	1,699	1,344	1,950	1,603	2,395	2,022	651	336
	2A2B			920	565	1,187	847	1,392	1,035	1,600	1,228	1,855	1,492	2,296	1,906	767	434
	2B					1,111	697	1,313	880	1,519	1,067	1,778	1,339	2,215	1,745	929	513
	2A3					1,051	570	1,251	747	1,455	931	1,717	1,210	2,151	1,609	1,067	576
	2C							1,182	607	1,383	786	1,649	1,071	2,080	1,464	1,213	646
	2C3									1,305	683	1,575	973	2,001	1,361	1,316	723
C45	2AB	1,203	699	2,030	1,445	2,517	1,956	2,939	2,347	3,364	2,746	3,840	3,235	4,699	4,047	1,173	636
	2A			1,900	1,213	2,396	1,739	2,813	2,122	3,235	2,513	3,716	3,013	4,570	3,814	1,408	764
	2A2B			1,800	1,033	2,302	1,571	2,716	1,948	3,134	2,334	3,621	2,842	4,469	3,634	1,589	862
	2B					2,153	1,305	2,560	1,671	2,974	2,049	3,468	2,571	4,308	3,349	1,876	1,020
	2A3					2,031	1,087	2,434	1,444	2,843	1,815	3,343	2,348	4,178	3,116	2,111	1,148
	2C							2,307	1,218	2,713	1,582	3,220	2,126	4,048	2,882	2,346	1,276
	2C3									2,586	1,348	3,099	1,904	3,921	2,649	2,581	1,400
C60	2AB	2,922	1,761	4,874	3,528	6,031	4,736	7,035	5,671	8,049	6,621	9,168	7,771	11,214	9,706	2,670	1,438
	2A			4,591	3,015	5,767	4,258	6,761	5,174	7,766	6,109	8,899	7,283	10,931	9,194	3,185	1,716
	2A2B			4,372	2,607	5,562	3,877	6,548	4,778	7,546	5,700	8,690	6,894	10,711	8,785	3,597	1,931
	2B					5,258	3,333	6,232	4,213	7,220	5,118	8,379	6,339	10,386	8,203	4,183	2,251
	2A3					4,958	2,790	5,920	3,649	6,899	4,536	8,073	5,785	10,064	7,621	4,769	2,566
	2C							5,634	3,129	6,603	4,000	7,792	5,275	9,768	7,085	5,309	2,857
	2C3									6,302	3,462	7,505	4,762	9,468	6,547	5,851	3,152
C75	2AB	5,468	3,607	9,083	6,915	11,213	9,120	13,066	10,856	14,935	12,619	17,015	14,738	20,779	18,314	4,534	2,583
	2A			8,556	6,014	10,721	8,279	12,556	9,982	14,409	11,718	16,514	13,880	20,253	17,413	5,441	3,099
	2A2B			8,154	5,327	10,345	7,638	12,165	9,317	14,006	11,031	16,130	13,227	19,850	16,727	6,132	3,495
	2B					9,739	6,602	11,535	8,239	13,356	9,921	15,512	12,169	19,200	15,616	7,251	4,132
	2A3					9,248	5,763	11,025	7,368	12,830	9,022	15,010	11,313	18,674	14,718	8,155	4,649
	2C							10,514	6,495	12,304	8,122	14,509	10,455	18,147	13,817	9,063	5,166
	2C3									11,777	7,223	14,008	9,599	17,621	12,918	9,967	5,682

See Page 10 for Spring Set combinations

Technical Data

Actuator size		Unit	C15	C20	C25	C30	C35	C45	C60	C75
Weight Spring Return	Kg		1.1	1.9	3.5	5	9	15	35	64
	Lb		2.4	4.2	7.7	11	19.8	33.1	77.2	141.1
Weight Double Acting	Kg		0.9	1.5	2.8	4.4	7.1	11	26	51
	Lb		1.98	3.3	6.2	9.7	15.7	24.3	57.3	112.4
Air Consumption per stroke	ccw	Litre	0.07	0.12	0.25	0.44	0.74	1.33	3.20	5.76
	cw		0.09	0.15	0.33	0.54	0.80	1.33	3.20	5.76
	Total		0.16	0.27	0.58	0.98	1.54	2.66	6.40	11.52
Air Consumption per stroke	ccw	In³	4.3	7.3	15	27	45	81	195	351
	cw		5.5	9.2	20	33	49	81	195	351
	Total		9.8	16.5	35	60	94	162	391	703
Stroke Time with S.V. with 0.9 Cv at 80 psi	D/A	Sec.	0.1	0.13	0.2	0.24	0.4	0.75	1.5	2.5
	S/R Open		0.1	0.15	0.23	0.29	0.54	1	2.2	3.7
	S/R Close		0.15	0.15	0.23	0.28	0.48	0.77	1.6	2.9

Pressure Range:

20-120 PSI (1.5 - 8 bar) for DA actuators
30-120 PSI (2 - 8 bar) for SR actuators

Operating Temperature:

Buna N: -20°C to 80°C (-4°F to 176°F)
Viton: -20°C to 120°C (-4°F to 250°F)
EPDM: -40°C to 80°C (-40°F to 176°F)

NAMUR & ISO Interface

NAMUR VDI/VDE 3845

This standard provides for a range of accessories such as limit switches, pucks, indicators and positioners which have VDI/VDE interface to be easily mounted onto the actuator top face.

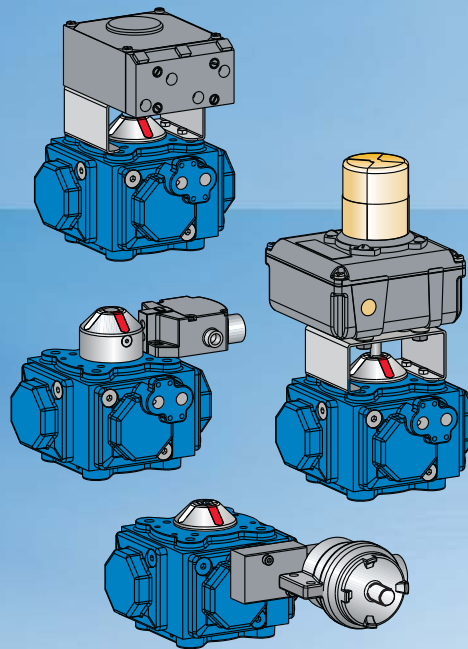

NAMUR Solenoid Mounting

One of the four covers of the actuator incorporates a pad for solenoid mounting according to the NAMUR international standard. Solenoids of any brand, conforming to the NAMUR interface can be directly mounted to the actuators. This simplifies the installation of solenoids and eliminates additional piping. It also allows quick actuation response as pressurized air supply is available at the port entrance.

ISO 5211 or DIN 3337

The actuator bottom flange is in accordance with ISO 5211 (or DIN 3337) international standard and incorporates a star shaped female drive for flexibility to fit various valve output shafts. The valve can be attached by a bracket or mounted directly onto the actuator, using one of the various ISO hole patterns.



Spring Combinations

OUTER

MIDDLE

INNER



C15 ONLY

CODE	Spring Combinations
1A	
1B	
1B2	
2	

C20-C75

CODE	Spring Combinations
2AB	
2A	
2A2B	
2B	
2A3	
2C	
2C3	
3	

Sizing a spring return actuator requires that the torque output at the start and end of both the spring and air drive strokes is greater than the valve torque at that position.

Actuator Dimensions

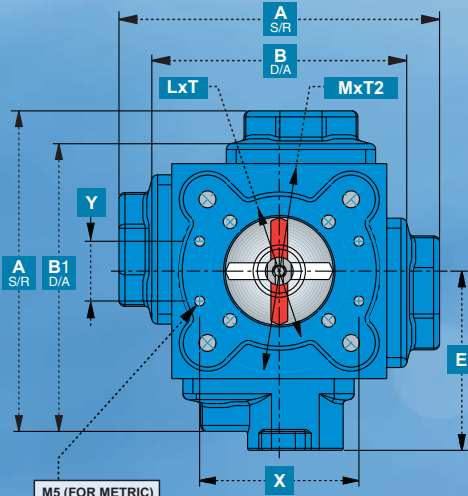

M5 (FOR METRIC)
 10/24 UNC
 (FOR IMPERIAL)

TOP VIEW C15 - C45

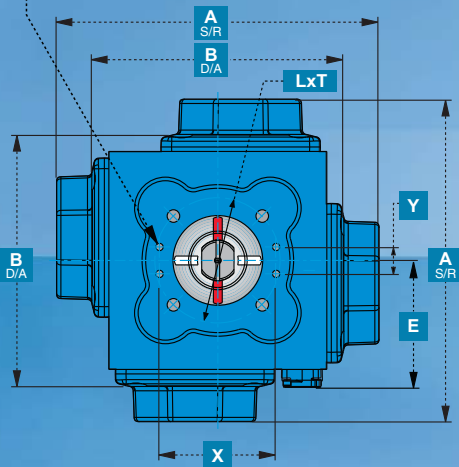

TOP VIEW C60 - C75

VDI/VDE 3845		PORT A connected to the center chamber	
SIZES	X x Y x h	PORT B connected to the outside chambers	
C15 - C45	80 x 30 x 20		
C60 - C75	130 x 30 x 30		

G - 1/4" ISO
 (FOR METRIC)
 1/4" NPT
 (FOR IMPERIAL)

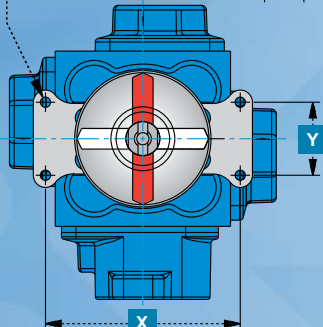

TOP VIEW C15 ONLY
 VDI/VDE Brackets on request

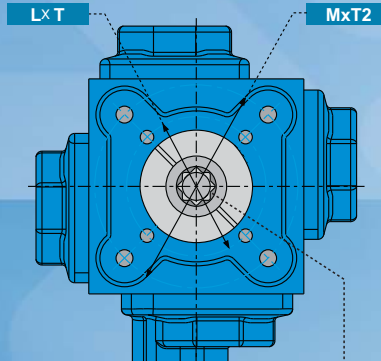

BOTTOM VIEW C15 - C75

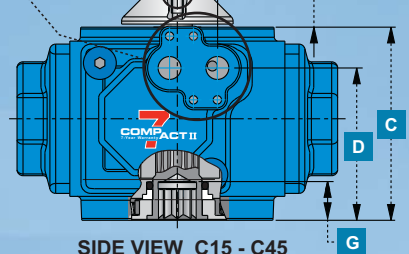
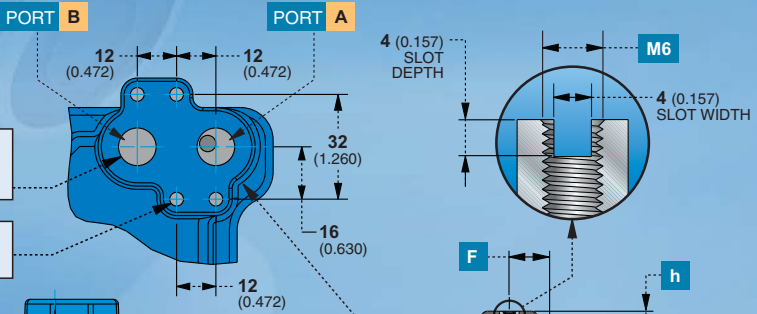
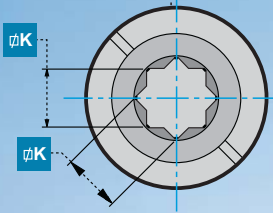

SIDE VIEW C15 - C45

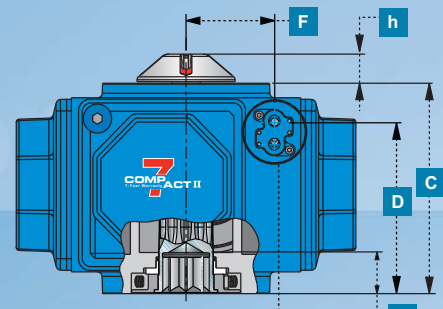

SIDE VIEW C60 - C75

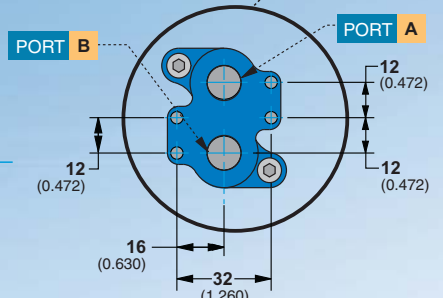

SIZE*	A		B		B1		C		D		E		F		G		phi K		L		T		M		T2	
	mm	inch	mm	inch	mm	inch	mm	inch	mm	inch	mm	inch	mm	inch	mm	inch	mm	inch	mm	inch	mm	inch	mm	inch	mm	inch
C15	110	4.31	86.0	3.39	97.8	3.85	68.8	2.71	50.8	2.00	66.0	2.60	16.0	0.63	13.5	0.53	9.0	0.35	50 (F05)	1.97 (F05)	M6x8	1/4"x0.314	-	-	-	-
C20	131	5.17	102	4.03	117	4.60	80.5	3.17	61.5	2.42	77.2	3.04	16.5	0.65	15.0	0.59	11.0	0.43	50 (F05)	1.97 (F05)	M6x8	1/4"x0.314	70 (F07)	2.76 (F07)	M8x11	5/16"x0.43
C25	161	6.34	132	5.24	147	5.79	97.0	3.82	76.5	3.01	90.0	3.54	20.0	0.79	19.5	0.77	14.0	0.55	70 (F07)	2.76 (F07)	M8x9	5/16"x0.354	102 (F10)	4.02 (F10)	M10x11	3/8"x0.43
C30	186	7.33	151	5.94	169	6.64	116	4.58	93.4	3.68	105	4.15	22.3	0.88	22.0	0.87	17.0	0.67	70 (F07)	2.76 (F07)	M8x11	5/16"x0.43	102 (F10)	4.02 (F10)	M10x12	3/8"x0.47
C35	222	8.74	182	7.15	202	7.94	135	5.31	102	4.02	114	4.48	22.5	0.89	26.0	1.02	22.0	0.87	102 (F10)	4.02 (F10)	M10x13	3/8"x0.51	-	-	-	-
C45	269	10.59	221	8.70	245	9.65	164	6.46	127	5.00	147	5.79	31.0	1.22	33.0	1.30	27.0	1.06	125 (F12)	4.92 (F12)	M12x15	1/2"x0.59	102* (F10)	4.02* (F10)	M10x15	3/8"x0.59
C60	360	14.17	285	11.22	-	-	218	8.58	180	7.09	141	5.57	94.0	3.70	43.0	1.69	36.0	1.42	140 (F14)	5.51 (F14)	M16x18	5/8"x0.71	-	-	-	-
C75	437	17.20	342	13.46	-	-	270	10.63	223	8.76	166	6.54	110	4.33	43.0	1.69	36.0	1.42	140 (F14)	5.51 (F14)	M16x18	5/8"x0.71	-	-	-	-

* The C45 bottom PCD can be either F12 or F10, but not both. The standard is F12. When ordering C45 with F10 you must add it to the code.

NAMUR & ISO Interface

An extensive range of accessories such as Solenoids, Positioners and Limit Switches are available for direct mounting to the **COMPACT II** actuator. As standard, all accessories which have connections that comply with ISO 5211 or DIN 3337 and VDI/VDE 3845 (NAMUR) mounting can be connected to the actuator.



Dome

The Dome is a weatherproof enclosure for the Compact pneumatic actuator and a variety of ancillary equipment, and represents a cost effective alternative to stainless steel actuators and all of the stainless ancillary equipment required in those applications.

The Dome is ideal for very corrosive environments with frequent caustic wash-downs, as well as clean antiseptic applications where mostly stainless equipment is required. The Dome can be mounted on any quarter turn valve, Ball, Butterfly or Plug.



Safety Features

The **Compact II** safety features are built in and ensure a secure and safe operation whereby assembly and dismantling of the actuator becomes a simple task. Long cover bolts for spring return actuators relieve the spring load before they disengage from their threads. Before pistons can be removed, the stop screw must be released and the pinion removed, thus ensuring that any trapped pressure in the body will escape and will not become a hazard.

Quality

The **Compact II** is manufactured under ISO 9001 certification and is **ATEX 94-9-EC** approved to category 2 for use in potentially explosive areas. All body and cover castings are identified by a stamped heat code.



Flow Directions

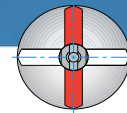

S (Straight)

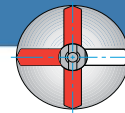

T (3-Way)

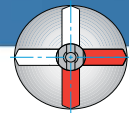

L (2-Way 90 DEG)
X (4-Way)

How to Order

When ordering the Compact II series actuator, please give all the information as specified below.

SIZE	TYPE	SPRINGS SET	THREAD	INDICATOR	OPTIONS
C15	SR - Spring Return	C15 C20 to C75	I Imperial	S Standard White with Red arrows	V Viton O-rings
C20	DA - Double Acting C75	1A 2AB 2A3	M Metric	D Red with White arrows	E EPDM O-rings
C25		1B 2A 2C		P Puck	N Electroless Nickel Coating
C30		1B2 2A2B 2C3		Flow :	U UHMWPE for Radiation
C35		2 2B 3		S Straight	RFS Reverse Fail Safe Actuator
C45				T 3-Way	
C60				L 2-Way 90 Deg	
C75				X 4-Way	

For more details of spring set combinations see page 10

Examples:

C35 SR 2C M-N Size C35, spring return, 2C spring set, metric thread, standard indicator, electroless nickel coating.
C60 DA I-DT-E Size C60, double acting, imperial thread, indicator red with white arrows, flow 3-Way, EPDM O-rings.

DELRIN® is a registered trademark of DuPont, **VESPEL**® is a registered trademark of DuPont, **KEL-F**® is a registered trademark of 3M Company
NYLATRON® is a registered trademark of Quadrant DSM Engineering Plastic Products, **TFM**™ is a trademark of Dyneon, **PEEK**® is a trademark of VICTREX

In accordance with our policy to strive for continuous improvement of the product, we reserve the right to alter the dimensions, technical data and information included in this catalogue when required.
 Copyright © 2009 HABONIM Ltd. All rights reserved



HABONIM USA
 Toll Free Phone: 1-866-261-8400
 Toll Free Fax: 1-866-243-9959
 sales_usa@habonim.com

HEADQUARTERS HABONIM ISRAEL
 Tel: +972-4-6914911
 Fax: +972-4-6914902
 sales_international@habonim.com

www.habonim.com