

INCH



FLANGED STANDARD BORE BALL VALVES

ANSI CLASS 150 & 300

31P/32P SERIES



DEDICATED TO INNOVATION

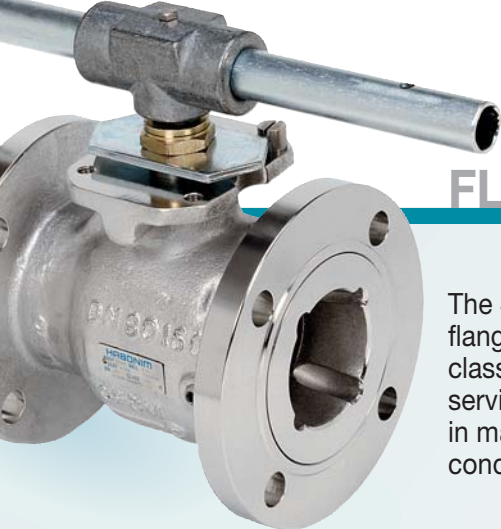

FLANGED STANDARD BORE BALL VALVES

The **31P/32P** Series are **HABONIM**'s line of one piece fully flanged reduced bore ball valves in ANSI class 150 and ANSI class 300. **HABONIM**'s flanged valves offer tight shutoff, long service life and high durability with exceptional performance in many service applications under the most severe working conditions.

Technical Summary

Size Range:	½" - 8"
Flange Connection:	31P Series - ANSI class 150 32P Series - ANSI class 300
Application:	Chemical, Petrochemical, Oil and Gas production, Refining, Energy, Pulp & Paper and others
Service:	Steam, Chemicals, LP-Gas, Thermal Fluid, Chlorine, Ammonia, Sour Gas
Materials:	Carbon Steel, Stainless Steel, Hastelloy-C22, Alloy-20, Monel, Duplex
Certifications:	Firesafe to API 607 4th Edt., EN 12266-1:2003, API 6FA, PED 97/23/EC, ATEX Directive 94/9/EC Lloyds Type Approved to BS 5351 & API 6D
Operation:	Hand or Gear operated, Pneumatic, or Electric Actuated

Construction

All valves are one piece design. The valve bodies have a top mounting flange conforming to ISO 5211 for direct mounting of actuators, limit switches, fugitive emission bonnets or extended handles.

Seats

Flexible seat design provides tight shutoff at high and low pressures, reduced wear and valve torque. A wide range of seat materials are available. Standard seat materials are Virgin PTFE, glass filled PTFE or carbon-filled PTFE. For other seat materials, please refer to Bulletin T-624, or consult with Habonim.

Stem

The valve stem assemblies have blowout proof stems with live loaded spring washers to compensate for pressure and temperature surges and wear.

Ball

A highly polished solid ball with a pressure relief hole in the stem slot to equalise the pressure in the body cavity ensures tight shutoff and long service life.

Body and Trim Materials

The standard valve body materials are 316 Stainless Steel and Carbon Steel grades WCB and LCB. Standard trim material for ball and stem is 316 Stainless Steel. Trim materials such as Monel, Hastelloy-C, Alloy-20, Duplex and others are available for specific applications.

Antistatic

The valve stem has a built in antistatic device which ensures continuous contact of stem-to-ball and stem-to-body.

Valve's Refinement

Carbon Steel valves are phosphated and oil dipped. Stainless Steel valves are natural finish.

Interchangeability

Valve ball, stem, seats and seals are interchangeable with the Habonim **47P/46 Series** three piece ball valves.

Fire Safe Valves

Fire Safe valves are designed and tested to the requirements of API 607 4th Edition and to BS 6755 Part 2 specifications. Valves for fire safe application are identified by the prefix "**AF**". Fire Safe certificates for valves should be requested, if required.

Secondary sealing

All fire safe valves are fitted with flexible graphite body seals and graphite stem seals.

The valves contain soft seat rings. In the event of fire, a secondary metallic machined ring comes in contact with the ball and prevents leakage through the valve port. The stem incorporates a machined ring shaped surface which will prevent leakage, once the thrust seal has been burnt off.

Special Service

Valves prepared for special services such as Dry Chlorine, Oxygen, Hydrogen Peroxide, Ammonia, Vacuum, Steam, Thermal fluids and low temperature service are in accordance with the relevant standards.

Other designs available include Control valves with V-Ported seats, Diverter valves, Steam Jacketed valves, Cryogenic valves and Double-Block & Bleed valves.

Sour gas service valves are to NACE MR-01-75.

Ask for the relevant bulletins for all these applications.

Other available accessories:

Stem extensions for valves.

Fugitive emission kits for hazardous fluids.

Locking devices for securing valve position.

Manual gear operators for operating large valves.

Declutchable gear operators for actuated valves.

Spring return handle (Dead man lever) for dependable automatic closing or opening of valves.

Limit switches for on-off indication.

Pressure / Temperature Rating (Seat Material)

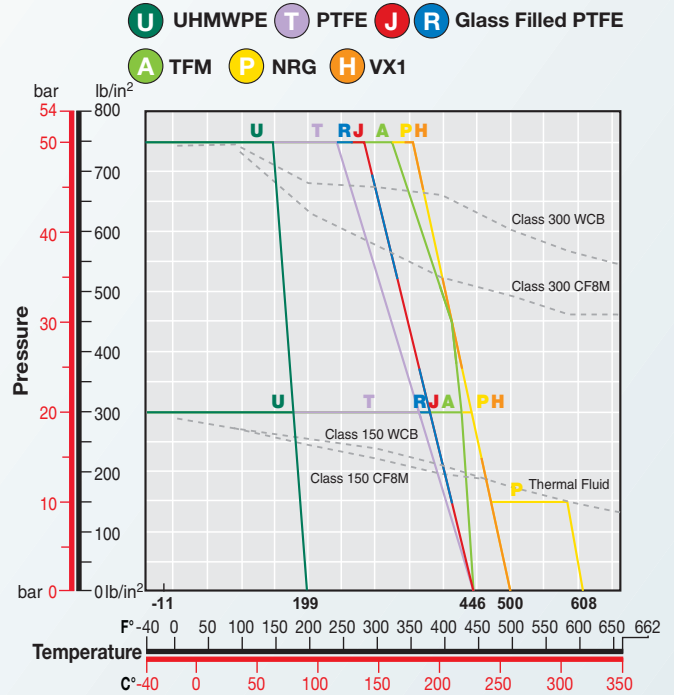
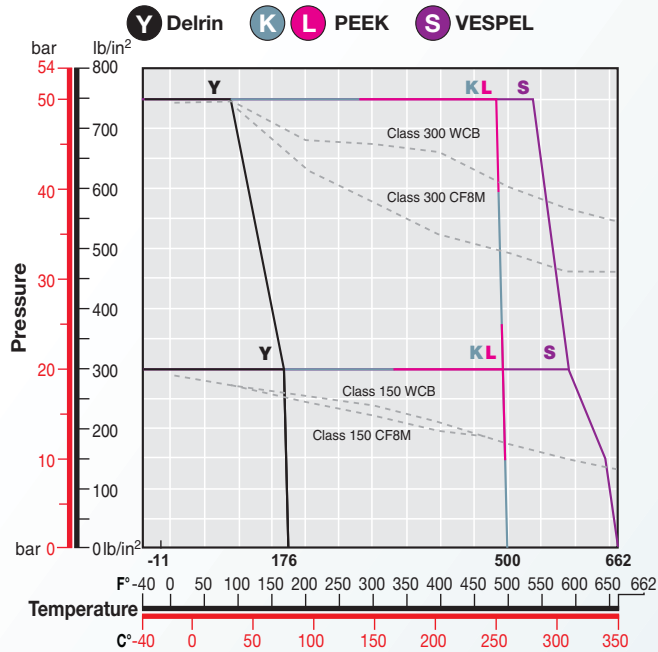

The pressure/ temperature rating is determined by the valve flanges and by the seat rating. Temperature ranges from -40°C to 350°C. Valves fitted with PEEK, DELRIN&VESPEL seats are assembled with PEEK, NYLATRON, VESPEL thrust seal accordingly and SS 17-4PH stem.

Valve Options

The HABONIM distinctive ability to engineer solutions for special applications has resulted in many designs. Some of the various valve designs and accessories that HABONIM have available with the 31P/32P series are shown below. For more information and other options, please consult with Habonim.

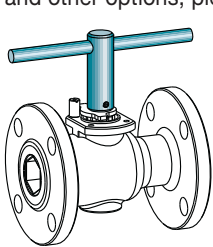

Extended Stem Handle
(See Bulletin C-514)

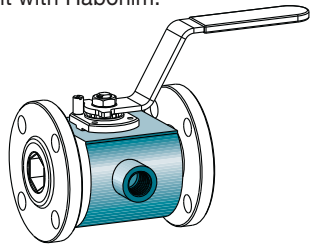

Steam Jacket
(See Bulletin C-511)

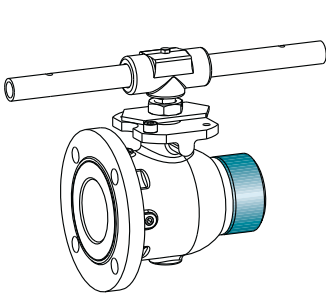

Butt weld End

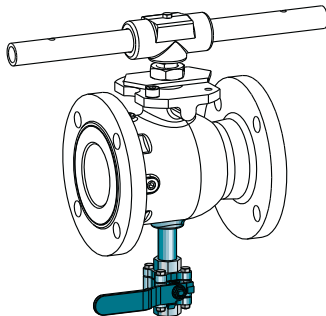

Double Block & Bleed

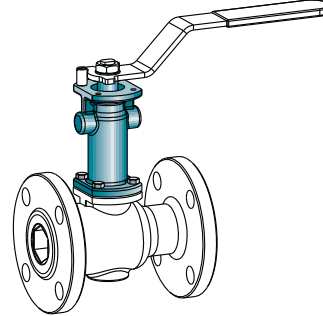

Fugitive Emission

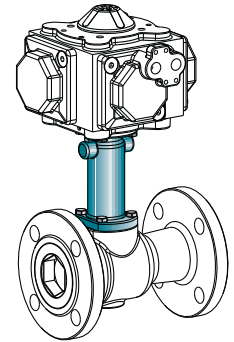

Fugitive Emission With Actuator

Valve Size	Cv Values		Limiting Stem Input Torque*			
	Flow Coefficients		316 S/S Stem material		17-4PH Stem material	
Inch	Cv	Kv	Nm	in-lb	Nm	in-lb
½"	7	6	13.2	117	91	805
¾"	10	9	13.2	117	91	805
1"	30	26	24.4	216	165	1,460
1½"	90	78	48.6	430	268	2,372
2"	130	112	48.6	430	268	2,372
3"	350	302	385	3,400	1,930	17,000
4"	720	621	385	3,400	1,930	17,000
6"	1,020	879	1,570	13,900	7,500	66,300
8"	1,880	1,552	1,570	13,900	7,500	66,300

Cv - Flow in US GPM at 1 psi pressure drop.

Kv - Flow in m³/hr at 1 bar pressure drop.

Valve flow rates are determined in full open position with water at 15°C (60°F).

* Limiting Stem torque figures are based on random laboratory tests.

These are not to be confused with valve operating torque.

FLANGED STANDARD BORE BALL VALVES

Valve Specification 1/2"-2"

Item	Description	Material Specifications	Qty.
1	Body	Stainless St. ASTM A351 CF8M, DUPLEX, ALLOY 20, HASTELOY C22, MONEL	1
2	Insert	Carbon St. ASTM A105	1
3	Ball	Stainless St. ASTM A351 CF8M, DUPLEX, ALLOY 20, HASTELOY C22, MONEL	1
4	Stem	Stainless St. ASTM A276 316/316L, DUPLEX, ALLOY 20, HASTELOY C22, MONEL	1
*5	Seat ring	PTFE, RPTFE, NRG, PEEK, TFM, VESPEL, DELRIN, UHMWPE	2
*6	Body seal	PTFE, RPTFE, TFM, UHMWPE, Graphite	1
*7	Stem thrust seal	RPTFE, NRG, PEEK, TFM, VESPEL, NYLATRON, UHMWPE	1
8	Stop pin	Stainless St. ASTM A582 303	2
*9	Stem packing	NRG, RPTFE, TFM, UHMWPE Graphite	1 2
10	Follower	Stainless St. ASTM B783 316L	1-2**
11	Disc springs	Stainless St. 17-7PH	2
	Stem nut	Stainless St. ASTM A194 316	1
13	Locking clip	Stainless St. ASTM A164 304	1
14	Handle	Stainless St. ASTM A240 430 Carbon St. Zinc plated	1
15	Serrated washer	Stainless St. 410	1
16	Handle nut	Stainless St. ASTM A194 316	1
17	Sleeve	Vinyl Plasticsol	1
18	Anti static spring	Stainless St. AISI 302	1
19	Anti static ball	Stainless St. AISI 304	1
20	LD housing	Stainless St. ASTM A351 CF8	1
21	LD stem	Stainless St. ASTM A351 CF8	1
22	LD spring	Stainless St. Music Wire	1
23	LD circlip	Spring Steel	1

* Standard items supplied in repair kits.

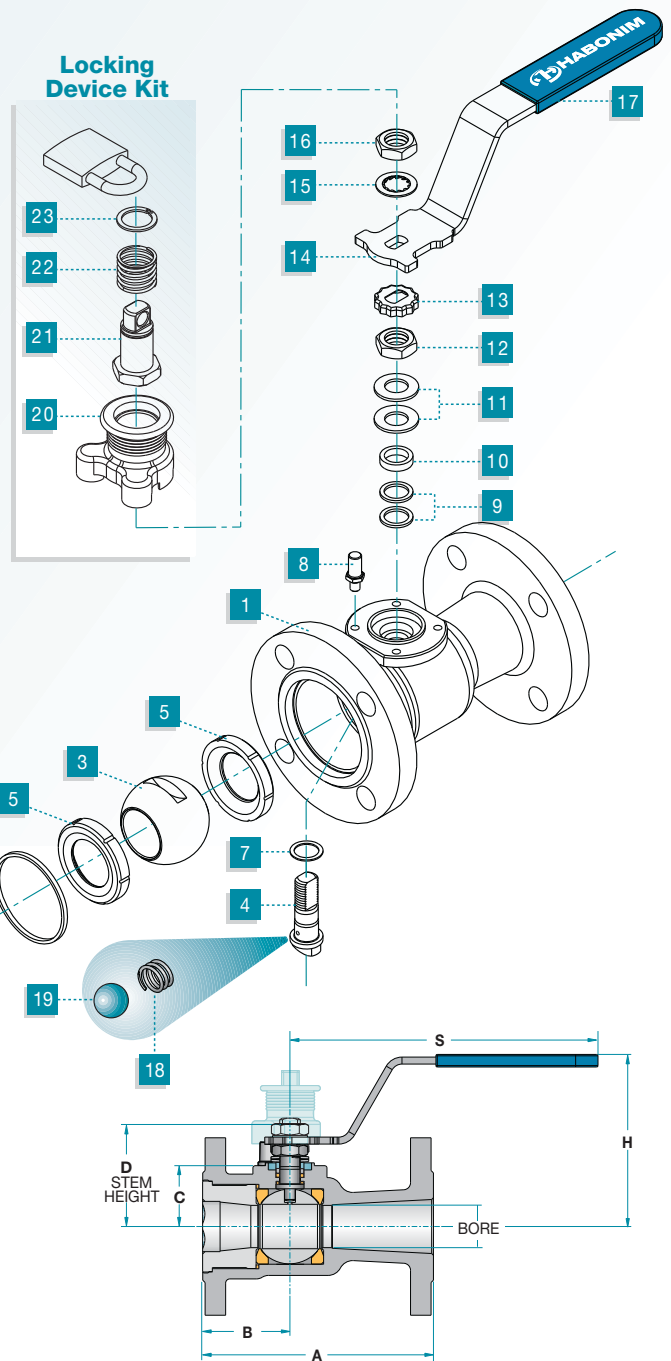

Stem dimensions

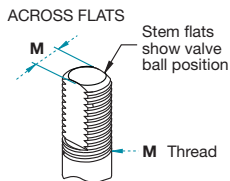

Preparation for actuation

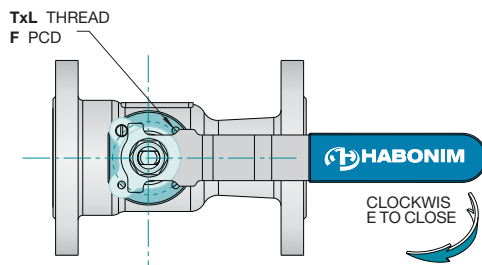
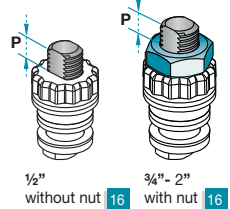

Valve Size	Bore Dia.	A			B	C	D	H	S	M	N	P	F	TxL	App. Weight kg./lb	
		150	300	150											300	
1/2"	mm	11.15	108.0	140	46.0	29.0	38.0	92.0	151.0	5.54	3/8"	11.1	36.0 (F03)	M5x10	1.7	2.4
	in	0.44	4.25	5.5	1.81	1.14	1.5	3.62	5.94	0.218	UNF	0.437	1.42		3.8	5.3
3/4"	mm	14.3	117.0	152.0	49.3	31.4	40.3	94.0	151.0	5.54	3/8"	11.1	36.0 (F03)	M5x10	2.3	3.3
	in	0.56	4.61	6.0	1.94	1.24	1.59	3.7	5.94	0.218	UNF	0.437	1.42		5.1	7.3
1"	mm	20.6	127.0	165.0	57.2	38.2	55.6	103.5	170.0	7.54	7/16"	15.4	42.0 (F04)	M5x10	3.3	4.6
	in	0.81	5.0	6.5	2.25	1.50	2.19	4.07	6.69	0.296	UNF	0.606	1.65		7.3	10.2
1 1/2"	mm	31.8	165.0	190.0	62.3	43.6	73.1	119.2	220.5	8.7	9/16"	19.6	50.0 (F05)	M6x12	5.5	8.7
	in	1.25	6.5	7.5	2.45	1.72	2.88	4.7	8.68	0.343	UNF	0.771	1.97		12.2	19.3
2"	mm	38.2	178.0	216.0	67.8	48.3	77.8	123.9	220.5	8.7	9/16"	19.6	50.0 (F05)	M6x12	8.1	10.8
	in	1.50	7.0	8.5	2.67	1.90	3.06	4.88	8.68	0.343	UNF	0.771	1.97		18.0	24.0

Valve Specification 3"-8"

Item	Description	Material Specifications	Qty.
1	Body	Stainless St. ASTM A351 CF8M Carbon St. ASTM A216 WCB	1
2	Insert	Stainless St. ASTM A351 CF8M Carbon St. ASTM A216 WCB	1
3	Ball	Stainless St. ASTM A351 CF8M	1
4	Stem	Stainless St. ASTM 276 316 / 316L	1
*5	Seat ring	PTFE, RPTFE, NRG, PEEK, TFM, VESPEL, DELTRIN, UHMWPE	2
*6	Body seal	PTFE, RPTFE, TFM, UHMWPE, Graphite	1
*7	Stem thrust seal	RPTFE, NRG, PEEK, TFM, VESPEL, NYLATRON, UHMWPE	1
8	Stop pin	Stainless St. ASTM A582 303 Carbon St. ASTM A29 GR 1020	1
*9	Stem packing	NRG, RPTFE, TFM, UHMWPE, Graphite	3
10	Followers	Stainless St. ASTM B783 316L	1
11	Stop Plate	Carbon St. ZINC plated	1
12	Tab lock washers	Stainless St. ASTM A240 304	1
13	Stem nut	Carbon St. ZINC plated	1
14	Wrench head	MALEABLE IRON	1
15	Wrench handle	Carbon St. ZINC plated	1
16	Wrench bolt	Stainless St. AISI 304	1
17	Insert retaining screws	Stainless St. DIN 914 A2-70	4-8
18	Anti static spring	Stainless St. AISI 302	2
19	Anti static plunger	Stainless St. AISI 304	2

The materials above are for standard applications. Other materials are available.
* Standard items supplied in repair kits.

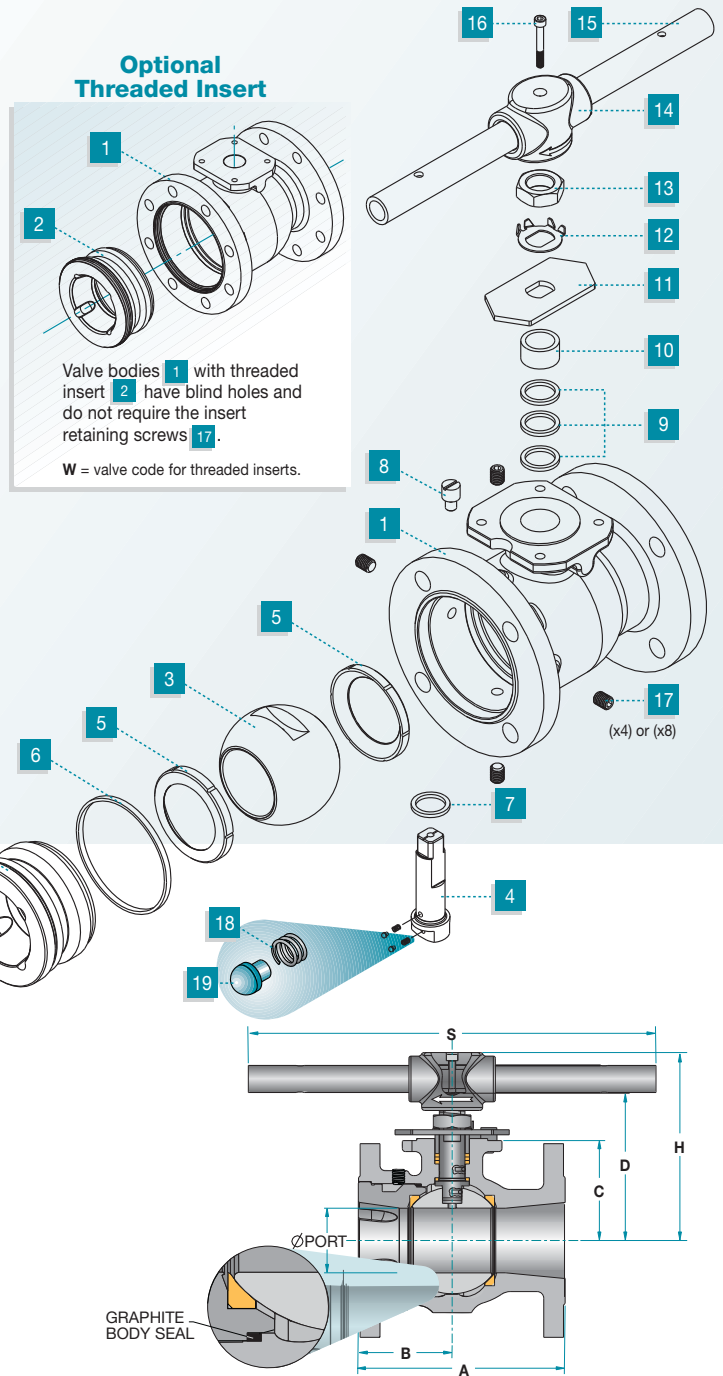

Stem Dimensions

Preparation for actuation

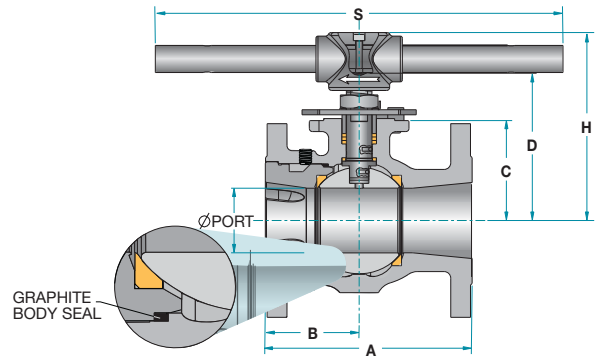
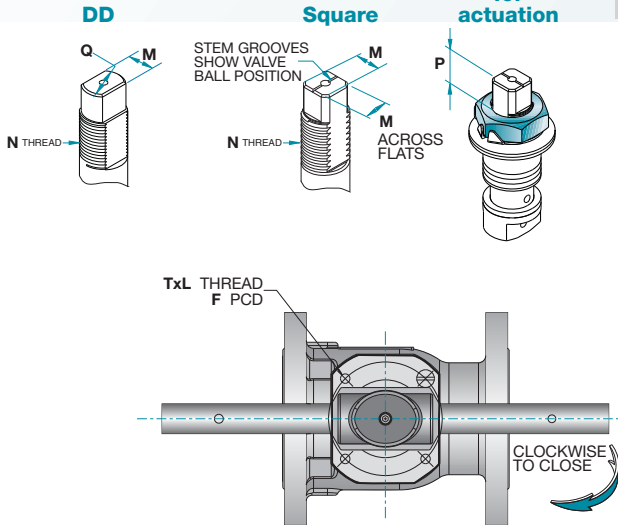

Valve Size	Bore Dia.	A		B	C	D	H	S	M	M-DD	N	P	F	TxL	App. Weight kg./lb		
		150	300												150	300	
3"	mm	63.5	203	284	92.1	98.4	145	185.1	400	18.9	15.9	1" - 14	16.7	102 (F10)	M10x20	18.0	22.7
	in	2.5	8.0	11.18	3.63	3.88	5.72	7.28	15.75	0.744	0.626	UNS - 2A	0.66	4.015		40.0	50.4
4"	mm	82.6	229	305	101.6	114.1	161	201	610	18.9	15.9	1" - 14	16.7	102 (F10)	M10x20	28.2	36.3
	in	3.25	9.0	12.0	4.0	4.49	6.34	7.91	24.01	0.744	0.626	UNS - 2A	0.66	4.015		62.8	80.6
6"	mm	111.1	267	403.2	108.0	157.4	226	285.9	916	28.4	23.75	1½" - 12	26.2	125 (F12)	M12x20	41.0	69.0
	in	4.38	10.5	15.88	4.25	6.20	8.91	11.25	36.08	1.112	0.935	UNF - 1A	1.03	4.921		91.0	153
8"	mm	144.4	292	419	163.5	185.2	254	313.6	916	28.45	23.75	1½" - 12	26.2	125 (F12)	M12x20	82.0	105
	in	5.68	11.5	16.5	5.37	7.30	10.0	12.34	36.08	1.118	0.935	UNF - 1A	1.03	4.921		182	233

FLANGED STANDARD BORE BALL VALVES

31P/32P Series Automated Valve Dimensions

Actuation

Where automation is required, the 31P/32P series ball valves are available with Habonim's unique 4-Piston pneumatic Compact actuator. The Compact actuator is available in 8 sizes, spring return or double acting. All the valve mounting flanges are according to ISO 5211 and are suitable for accommodating any quarter turn actuator (pneumatic or electric) for valve automatization. Valves can be operated for on-off or throttling application. The actuators have a NAMUR air connection interface for attaching solenoids. Limit switches and positioners can be mounted on the actuator top face according to VDI / VDE 3845. For information, please refer to Bulletin B360.

Sizes 1/2" - 2"

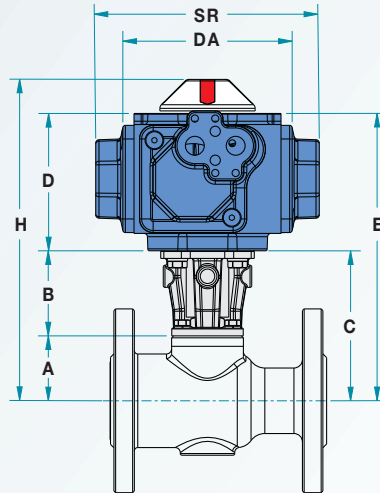

Sizes 3" - 8"

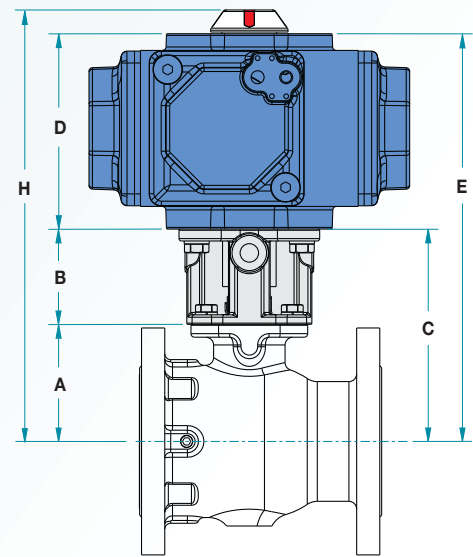

Valve Size	Actuator size	31P/32P Series					Compact Actuator		
		A	B	C	E	H	D	DA	SR
1/2" F03	C15	1.142	1.575	2.717	5.433	6.220	2.717	3.386	4.331
	C20		1.575	2.717	5.894	6.681	3.177	4.016	5.157
	C25		1.575	2.717	6.543	7.331	3.827	5.197	6.339
3/4" F03	C15	1.236	1.575	2.811	5.528	6.315	2.717	3.386	4.331
	C20		1.575	2.811	5.988	6.776	3.177	4.016	5.157
	C25		1.575	2.811	6.638	7.425	3.827	5.197	6.339
1" F04	C30	1.504	1.575	2.811	6.638	7.425	3.827	5.197	6.339
	C15		1.969	3.472	6.189	6.976	2.717	3.386	4.331
	C20		1.969	3.472	6.650	7.437	3.177	4.016	5.157
1 1/2" F05	C25	1.717	1.969	3.472	7.299	8.087	3.827	5.197	6.339
	C30		1.969	3.472	8.063	8.850	4.591	5.945	7.323
	C35		2.362	4.079	7.256	8.043	3.177	4.016	5.157
2" F05	C25	1.902	2.362	4.079	7.906	8.693	3.827	5.197	6.339
	C30		2.362	4.079	8.669	9.457	4.591	5.945	7.323
	C35		2.362	4.079	9.413	10.201	5.335	7.165	8.740
3" F10	C25	3.870	2.362	4.264	7.441	8.228	3.177	4.016	5.157
	C30		2.362	4.264	8.091	8.878	3.827	5.197	6.339
	C35		2.362	4.264	8.854	9.642	4.591	5.945	7.323
4" F10	C45	4.492	2.362	4.264	9.598	10.386	5.335	7.165	8.740
	C30		3.150	7.020	11.610	12.398	4.591	5.945	7.323
	C35		3.150	7.020	12.354	13.142	5.335	7.165	8.740
6" F12	C45	6.197	3.150	7.020	13.476	14.264	6.457	8.701	10.591
	C60		3.150	7.020	15.583	16.764	8.563	11.220	14.173
	C75		3.150	7.020	17.642	19.453	10.630	13.465	17.205
8" F12	C35	7.287	3.150	7.642	12.976	13.764	5.335	7.165	8.740
	C45		3.150	7.642	14.098	14.886	6.457	8.701	10.591
	C60		3.150	7.642	16.205	17.386	8.563	11.220	14.173
	C75	3.150	7.642	18.272	19.453	10.630	13.465	17.205	
	C35	3.937	10.134	15.469	16.256	5.335	7.165	8.740	
	C45	3.937	10.134	16.591	17.378	6.457	8.701	10.591	
	C60	3.937	10.134	18.697	19.878	8.563	11.220	14.173	
	C75	3.937	10.134	20.764	21.945	10.630	13.465	17.205	
	C45	3.937	11.224	17.681	18.469	6.457	8.701	10.591	
	C60	3.937	11.224	19.787	20.969	8.563	11.220	14.173	
	C75	3.937	11.224	21.854	23.035	10.630	13.465	17.205	

Actuator Sizing

Valve sizing tables of the Compact actuators on Habonim valves are available on request.

The sizing tables are based on valve size, differential pressure, valve seat types, working temperature, flowing media and frequency of operation.

The valve torque figures are calculated from tests using water at room temperature at different pressure drops for each seat material and actuator air pressure.

Please consult with HABONIM for more details.

Flanged Valve Sizing Table

The following sizing table is for Class 150 and 300 valves with PTFE seats at ambient temperatures and 10 bar pressure drop and is for reference only.

Valve Size	Double Acting (DA)			Spring Return (SR)		
	60 psi	80 psi	100 psi	60 psi	80 psi	100 psi
1/2"	C15	C15	C15	C20-2A2B	C15-1B2	C15-2
3/4"	C15	C15	C15	C20-2A2B	C15-1B2	C15-2
1"	C20	C15	C15	C25-2A2B	C20-2C	C20-3
1 1/2"	C20	C20	C20	C30-2A2B	C25-2C	C25-3
2"	C25	C25	C20	C30-2A2B	C30-2C	C25-3
3"	C35	C30	C30	C45-2A2B	C35-2C	C35-3
4"	C45	C35	C30	C60-2A2B	C45-2C	C45-3
6"	C60	C45	C35	C75-2A2B	C60-2C	C60-3
8"	C75	C60	C45	CONSULT	C75-2C	C75-3

Mounting Actuators or Gear Operators

When preparing a valve for actuation, make sure to follow the instructions below.

Stem arrangement for actuated valves

Valve sizes 1/2" to 2".

Release the wrench nut **1** and serrated washer **2**, remove the wrench **3** and refasten the wrench nut on the tab washer **4**. Remove the stop pin **5**. Valve sizes 1/2" and 2" do not require the wrench nut **1**.

Manual Valve stem assembly

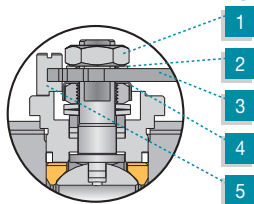

Actuated Valve stem assembly

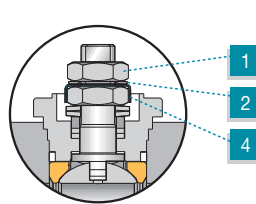

Valve sizes 3" to 8".

Release the wrench bolt **1** and remove the wrench handle **2**, wrench head **3**, gland nut **4** and stop plate **5**. Assemble the two disc springs **6**, stem location ring **7**, tab **8**, washer **9** and refasten the non-slotted gland nut.

Manual Valve stem assembly

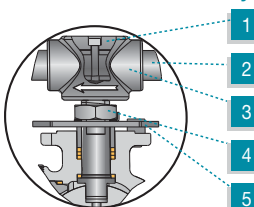

Actuated Valve stem assembly

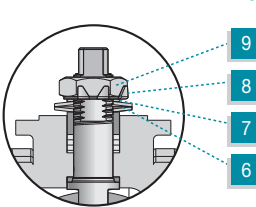

Valve Installation

Habonim flanged valves are delivered in the open position and with flange protection covers. Flanged valves are installed directly into the pipe line. When installing the valves in-line, follow the bolt tightening patterns shown below, using the recommended torque figures for safe operation. For more information, please refer to the Installation, Operation and Maintenance manual of the Habonim Flanged valves.

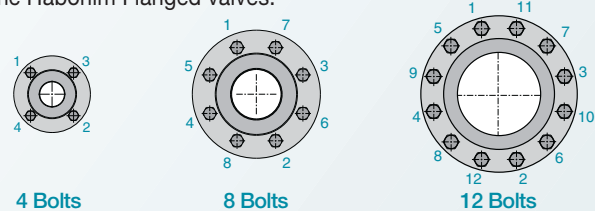

Valve Size (in)	Valve Size (DN)	ANSI 150		ANSI 300	
		Nm	in.lb	Nm	in.lb
1/2"	15	80	710	80	710
3/4"	20	80	710	140	1,240
1"	25	80	710	140	1,240
1 1/2"	40	80	710	240	2,120
2"	50	140	1,240	140	1,240
3"	80	170	1,500	250	2,210
4"	100	170	1,500	250	2,210
6"	150	170	1,500	250	2,210
8"	200	170	1,500	420	3,720

Locking Device

LLP (Locked in Last Position)

The Habonim spring loaded locking device (LD) is ideal for applications where it is critical to keep the valve position without the risk of accidental operation.

The locking device fits easily to the valve stem by simply removing the stem nut and threading the lock stem above the handle. The LD can lock the valve in the closed or open position. The LD can be fitted to the valve in-line.

Available in sizes 1/2" to 2".

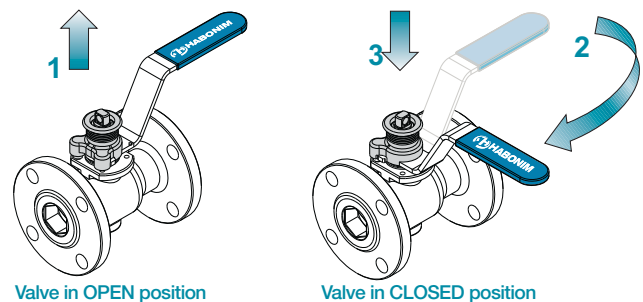

Antistatic Device

The antistatic device discharges static electricity buildup on the ball, conforming to BS 5351 for continuous electrical contact between ball/stem and stem/body. The contact is made by a spring loaded stainless steel element inserted in the stem or a conductive PTFE stem seal.

Valve sizes up to 2" feature a stem/body contact, while larger size valves have also a ball/stem contact.

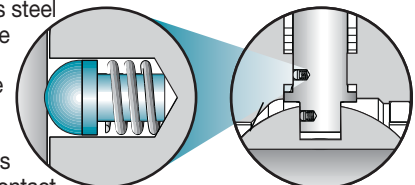

FLANGED STANDARD BORE BALL VALVES

31P&32P SERIES

How to order The HABONIM 31P&32P Identification Code

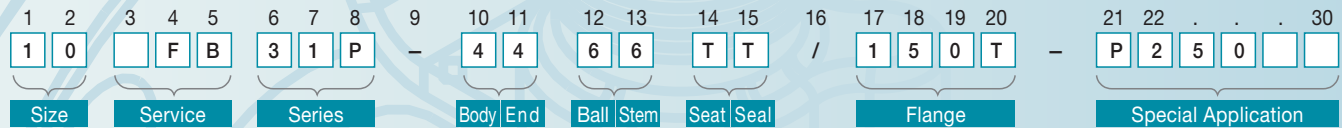

31P
32P

Size		
Code	inch	mm
05	1/2"	15
07	3/4"	20
10	1"	25
15	1 1/2"	40
20	2"	50
30	3"	80
40	4"	100
60	6"	150
80	8"	200

Service	
A	Antistatic
C	Cryogenic
D	Diverter Bottom entry
F	Firesafe
K	Dry Chlorine
N	Control
O	Oxygen
Q	Cavity filler
S	Diverter Side entry
V	Vacuum
W	Steam & Thermal fluid
X	Metal seats

Body / End Ball / Stem	
4	Carbon Steel
6	S. St. 316 (L)
7	Monel
8	S. St. 304
9	C. Steel LCB
A	Alloy-20
C	Hastelloy-C
D	Duplex
M	S. St. 17-4PH
Z	Inconel 718
W	Hastelloy-C22
K	Super Duplex
S	254SMO

Seat	
A	TFM
C	PCTFE
F	PFA
H	VX1
J	Reinforced 25% Glass filled PTFE
K	PEEK®
L	Virgin PEEK®
M	Metal
P	NRG
R	Reinforced 15% Glass filled PTFE
S	VESPEL®
T	PTFE
U	UHMWPE
Y	Derlin®

Seal	
G	Expended Graphite
I	Impregnated Graphite
M	S. St O-Ring
R	Reinforced 15% Glass filled PTFE
T	PTFE
U	Uhmwpe
V	Viton®

Flange	
150	ANSI 150 RF
300	ANSI 300 RF
FF	Flat Face
PN16	ANSI RF
PN40	Drilled to DIN
BW	Buttweld neck

Special Application	
90°	Diverter ball valve 90° turn
180°	Diverter ball valve 180° turn
A0866	Stem seal Ammonia service
P043	Stem seal for gas service
F043	Stem seal Neoprene
P250	Ball with Pressure relief hole
J2N05	Jacketed valve, No. of Outlets, Type, Size
V60	Characterized control seat
VB30	Characterized control ball
DBB	Double Block & Bleed
NACE	Nace service
W	Threaded Insert
R	DD Stem
HC	High Cycle stem arrangement
SRS	Self Relieving Seat
DHN	DHN coating

Other end connections are available on request.

In some applications the available options above are limited to specific sizes. Please consult with Habonim for details.

Standards of Compliance	
Flanges:	ANSI B16.5 Raised Face BS 1560 class 150, 300
Face-to-Face:	ANSI B16.10 Short Pattern
Antistatic:	BS 5351
Design:	LR Type App. BS 5351&API 6D ANSI B16.34, BS 5159
Pressure Testing:	API 598 ISO 5208, EN 12266-1:2003
Fire Testing:	API 607 4th Edt. API 6FA EN 12266-1:2003
NACE (option must be specified)	MR0175
Quality Assurance:	ISO 9001-2008
Certification:	PED 97/23/EC ISO -10474 DIN EN 10204 3.1.B ATEX Directive 94/9/EC

How to order

When placing an order for HABONIM valves, please provide as many details possible on the application such as: Media, Temperature, Pressure, Pipe line size and type of connection.

Example: 10 AF31P - 4466TG / 150- P250

Size 1" (10), Antistatic (A), Firesafe (F), Reduced Bore ANSI 150 (31P), C. St. Body & Insert (4), S. St. 316 Ball & Stem (6), PTFE Seats (T), Graphite Body Seals (G), ANSI 150 RF Flange (150), Ball with pressure relief hole (P250).

Quality Assurance

As an ISO 9001- 2008 certified company, Habonim operates according to internal manufacturing specifications that are written for each application and for specific customers. From the design stages to final inspection of assembled valves, Habonim controls its procedures for the integrity of the parts, their manufacturing process, storing and preservation and final assembly, to keep the highest standards of perfection of the product. All valves are 100% leak tested before packaging. Each valve is tagged for traceability and material certification can be provided on request.

DELTRIN® is a registered trademark of DuPont, VESPEL® is a registered trademark of DuPont, KEL-F® is a registered trademark of 3M Company NYLATRON® is a registered trademark of Quadrant DSM Engineering Plastic Products, TFM™ is a trademark of Dyneon, PEEK® is a trademark of VICTREX In accordance with our policy to strive for continuous improvement of the product, we reserve the right to alter the dimensions, technical data and information included in this catalogue when required.

Copyright © 2009 HABONIM Ltd. All rights reserved



HABONIM USA
Toll Free Phone: 1-866-261-8400
Toll Free Fax: 1-866-243-9959
sales_usa@habonim.com

HEADQUARTERS HABONIM ISRAEL
Tel: +972-4-6914911
Fax: +972-4-6914902
sales_international@habonim.com

www.habonim.com

CAT31P-2111 10/09

